

NEW

**300**  
S E R I E S

**616 Auto**



\* Illustration may contain items not standard to the model

**New ADR 80/03 Model  
Wide Cab 4 x 2 Cab Chassis**

## KEY FEATURES

- Dual SRS Airbags
- Disc Brakes
  - Front & Rear
  - ABS, VSC & TRC – all STD
- Energy Absorbing Steering Wheel
- ADR 80/03 Emission using Euro 5
- Also meet EEV emission levels
- Driver's suspension seat

## KEY SPECIFICATIONS

<b>GVM</b> . . . . .	.4495kg, optional 5500kg
<b>GCM</b> . . . . .	7300kg
<b>Engine</b> . . . . .	4.0-litre, Common Rail, Direct Injection, Turbocharged and Intercooled
<b>Power</b> . . . . .	110kW (150PS) @ 2500 RPM (ISO NET)
<b>Torque</b> . . . . .	420Nm @ 1400 RPM (ISO NET)
<b>Wheelbase</b>	Short . . . . . .2810mm Medium . . . . . .3430mm
<b>Nominal Max Body length</b>	Short . . . . . .3850mm Medium . . . . . .4840mm





# 616 Auto

## Engine & Driveline specifications

### ENGINE

Engine . . . . .	Hino N04C US
Max output (ISO Net) . . . . .	110kW (150 PS) @ 2500 RPM
Max torque (ISO Net) . . . . .	420Nm (42.8 kgf/m) @ 1400 RPM
Maximum engine speed . . . . .	3100 RPM
Type . . . . .	Diesel, four cycle, four-cylinder in line, overhead valve, water cooled
Combustion system . . . . .	Direct injection type
Bore & stroke . . . . .	104 x 118mm
Piston displacement . . . . .	4.009 litres
Fuel injection system . . . . .	Electronic control, common rail type
Air intake system . . . . .	Turbo-intercooled, front air intake
Air cleaner . . . . .	Paper element
Fan clutch . . . . .	Equipped
Exhaust system . . . . .	Catalytic Convertor with Diesel Particulate Active Reduction System (DPR)
Exhaust outlet . . . . .	Horizontal
Emission control system . . . . .	EGR & DPR meeting ADR 80/03 using Euro 5 Also meets EEV emission levels

### TRANSMISSION

Auto . . . . .	A860E
Type . . . . .	Automatic six speed with double overdrive

### BRAKES

Service brakes . . . . .	Hydraulic system with ventilated disc brakes front and rear
Control . . . . .	Vacuum servo with hydraulic assist & dual circuits
Front disc diameter . . . . .	296mm
Rear disc diameter . . . . .	281mm
Anti-lock system (ABS) . . . . .	Equipped
Vehicle Stability Control . . . . .	Equipped
Traction Control . . . . .	Equipped
Exhaust Brake . . . . .	Electric-vacuum actuator with valve in exhaust pipe
Park Brake . . . . .	Rear of transmission

### PERFORMANCE & GEAR RATIOS

Engine RPM @ 100km/h . . . . .	2170
Maximum speed (km/h) . . . . .	143
Gradeability tan $\theta$ % @ GVM . . . . .	60.0
Final drive ratio . . . . .	4.625:1

#### A860E

1st . . . . .	.3.743	5th . . . . .	.0.773
2nd . . . . .	.2.003	6th . . . . .	.0.634
3rd . . . . .	.1.343	Rev. . . . .	.3.697
4th . . . . .	.1.000		

### AXLE LOAD & TYRE LOAD LIMITS

Front axle . . . . .	2600kg
Tyres . . . . .	2360kg
Rear axle . . . . .	4400kg
Tyres . . . . .	4400kg
Front axle type . . . . .	I Beam
Rear axle type . . . . .	SH12 full-floating, single reduction, single speed by Hypoid gears

### SUSPENSION

#### Front suspension

Leaf . . . . .	Semi-elliptic taper leaf spring with shock absorbers and stabiliser
Spring dimensions, span & width . . . . .	1250mm x 70mm

#### Rear suspension

Leaf . . . . .	Semi-elliptic main and auxiliary tapered leafsprings with silencers and shock absorbers
Spring dimensions, span & width . . . . .	1300mm x 70mm
Auxiliary springs . . . . .	900mm x 70mm

### WHEEL & TYRES

Wheel type . . . . .	5-stud disc wheel
Wheel & rim size . . . . .	195/85R16 114/112
Number of tyres . . . . .	Seven including spare
Spare tyre carrier . . . . .	Equipped

### ELECTRICAL

Type . . . . .	24 volt, negative earth
Batteries . . . . .	12V x 2, series connected
Alternator type . . . . .	Built-in rectifier and voltage regulator
Capacity . . . . .	24V – 80 Amp
Starter capacity . . . . .	24V, 4.5kW



# 616 Auto

## Cab equipment & Instrumentation

### CHASSIS FRAME

Type . . . . .	Ladder-shaped channel section side rails
Chassis width at rear . . . . .	750mm
Max. section (depth x flange x thickness) . . . . .	190.8 x 65 x 4.9mm
Tensile strength . . . . .	540N/mm <sup>2</sup>
Towing hooks . . . . .	Equipped at front and rear
Front bumper . . . . .	Painted to cabin colour

### CAB EXTERIOR

Type . . . . .	Forward control, all steel welded construction, torsion-bar tilt mechanism, fully trimmed
Windscreen wipers . . . . .	Electric, dual wipers, intermittent and 2-speed
Outside rear mirrors . . . . .	Remote control & heated
Radiator grille . . . . .	Painted same colour as cabin
Lamps . . . . .	Halogen headlamps, fog lamps

### CAB INTERIOR

Steering . . . . .	Telescopic tilt column with integral power steering
Windscreen glass . . . . .	Laminated glass
Seating capacity . . . . .	Three
Driver's seat . . . . .	4-way adjustable, urethane foam pads, high-back seat, lumbar support & suspension base
Assistant's seat . . . . .	Fixed bench, urethane foam pads, high-back seat
Seat cover . . . . .	Fabric cover
<b>Seat belts</b>	
Driver's seat . . . . .	3-point type with ELR and pre-tensioner
Assistant's seat . . . . .	3-point type with ELR and pre-tensioner
Centre passenger's seat . . . . .	2-point type
Sun visors . . . . .	For driver and passenger
Ventilator . . . . .	Forced type by electric blower
Inside rear mirror . . . . .	One, flat type
Cigarette lighter (24 volt) . . . . .	Equipped
Audio . . . . .	DAB AM/FM radio with CD/DVD player & Bluetooth
Heater and defroster . . . . .	Equipped
Air conditioner . . . . .	Equipped
Remote door locking . . . . .	Equipped
Immobiliser . . . . .	Equipped
Power windows . . . . .	Equipped
SRS airbag . . . . .	Equipped for driver & left side passenger
Seat back console . . . . .	Equipped (centre)
Overhead consoles . . . . .	For driver and assistant
Cup holder . . . . .	Equipped

### POWER & TORQUE CHART (ISO Net) N04C US

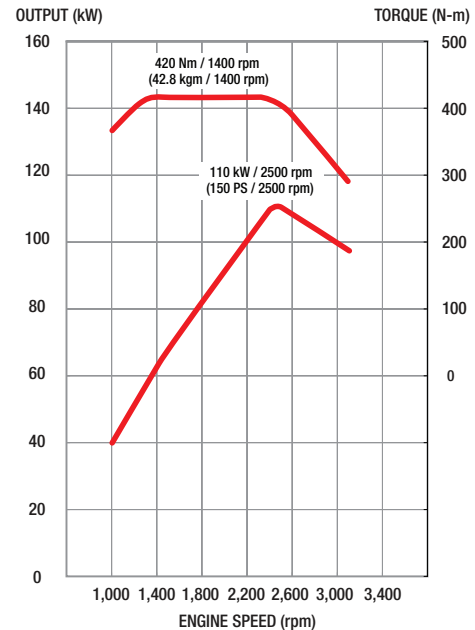

### INSTRUMENTS

- |   |                                     |
|---|-------------------------------------|
| <b>1. Meters and gauges</b>                       | <b>3. Switches</b>                  |
| km-kg system                                      | Lighting switch                     |
| Engine tachometer                                 | Wiper and washer switch             |
| <b>2. Warning, pilot lamps and buzzers</b>        | Exhaust brake switch                |
| Turning signal & hazard indicator lamp            | Traction Control OFF                |
| Exhaust brake indicator lamp                      | <b>4. Multi Information Display</b> |
| Engine oil pressure warning lamp                  | Fuel gauge                          |
| Battery charge warning lamp                       | Coolant temperature gauge           |
| High beam indicator lamp                          | DPR accumulation gauge              |
| Parking brake indicator lamp                      | Odometer                            |
| Engine malfunction indicator lamp                 | 2 trip meters                       |
| Fuel level warning lamp                           | Fuel consumption                    |
| Fuel filter water accumulating level warning lamp | - Current                           |
| Brake fluid level warning lamp                    | - Average                           |
| Back-up warning buzzer                            | <b>5. Others</b>                    |
| Cab-tilt warning lamp                             | One-key starting-stopping           |
| ABS system failure warning lamp                   | Horn button                         |
| SRS airbag system failure warning lamp            | Remote door locking                 |

### STEERING

Type . . . . .	Telescopic and tilt steering column with locking device. Recirculating ball with integral power steering
Steering angle . . . . .	<b>Inside:</b> 51° <b>Outside:</b> 36°



# 616 Auto Dimensions

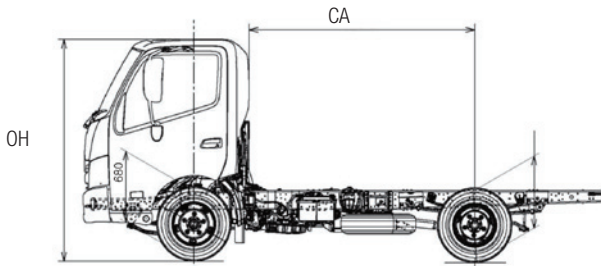
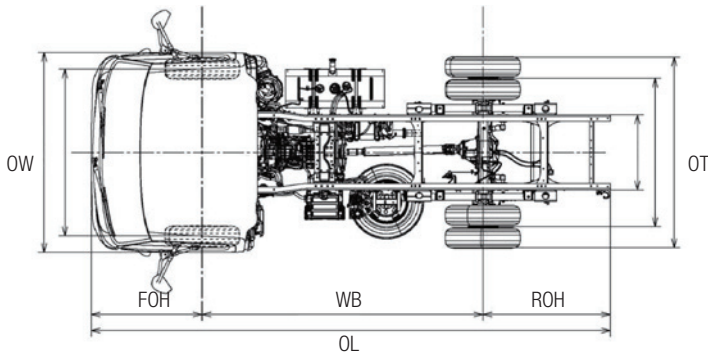

## DIMENSIONS – mm / Capacities

Model	616 Short Auto	616 Medium Auto
Product code	XZU700R-HKTMSQ3	XZU710R-HKTMSQ3
Wheelbase (WB)	2810	3430
Nominal Max Body length	3850	4840
Overall tyre width (OT)	1900	1900
Overall length (OL)	5195	6185
Overall width (OW)	1995	1995
Overall height (OH)	2195	2190
Front track	1665	1665
Rear track	1480	1480
Cab to axle centre (CA)	2250	2870
Front overhang (FOH)	1110	1110
Rear overhang (ROH)	1280	1645
Front chassis height	680	680
Rear chassis height	750	750
Road clearance	170	165
Turning circle – m (kerb-to-kerb)	9.8	11.8
Turning circle – m (wall-to-wall)	11.2	13.2
Fuel tank - lt	100	170

**Indicative chassis mass – kg** (standard tools, 10 litres of fuel, without spare tyre)

Total	2225	2320
Front	1580	1625
Rear	645	695
GVM*	5500	5500
GCM	7300	7300

\*Std GVM = 4495 OPT 5500

## GENUINE ACCESSORY OPTIONS

Bull bar	Roof scoop
Chrome wheel covers	Side skirts
GPS sat nav	Stoneguard
Rear vision camera (up to 3)	Sunvisor

Please check with your dealer for price, availability & fitment for these options

## WARRANTY

New vehicle warranty period

Light Duty Model	Axle configuration	Standard warranty (whichever comes first)	Cab corrosion perforation
300 616 Auto	4 x 2	3 years or 100,000km	36 months

Battery warranty – 12 months from date of delivery

Genuine parts or accessories warranty – 3 years unlimited kilometres when fitted by an authorised Hino dealer \*

\* For conditions, refer to the Hino Parts & Service warranty brochure

## DISCLAIMER

Important notice. Hino Trucks are distributed in Australia by Hino Motor Sales Australia Pty Ltd A.C.N. 064 989 724.

All efforts have been made to ensure the information contained in this brochure was correct at time of printing or uploading. Hino Motor Sales Australia Pty Ltd reserves the right to alter any details of the specifications & equipment without notice. Hino in so far as it is permitted by law to do so, shall not be liable in any way as a result of any reliance placed by any person on anything contained in this brochure. You should therefore check with your authorised Hino dealer at the time of ordering your motor vehicle to ensure that colour, specifications, equipment, design features & options are available for the vehicle you are ordering. Please note that some options may only be available in combination with others. Authorised Hino dealers will on request provide up to date information on all accessories, design features, prices & availability.

Date of issue - 01/10/11 616 Auto v3.1