



**ADR 80/03 Model**

**Standard Cab 4 x 2 Cab Chassis**

\* Illustration may contain items not standard to the model

## KEY FEATURES

- Dual SRS Airbags
- Easy Start – Take Off Assist
- Disc Brakes
  - Front & Rear
  - ABS, VSC & TRC – all STD
- Energy Absorbing Steering Wheel
- ADR 80/03 Emission using EURO 5
- Also meets EEV emission levels

## KEY SPECIFICATIONS

<b>GVM.</b>	. . . . .	.4495kg, optional 5500kg
<b>GCM.</b>	. . . . .	.7795kg, optional 9000kg
<b>Engine.</b>	. . . . .	.4.0-litre, Common Rail, Direct Injection, Turbocharged and Intercooled
<b>Power</b>	. . . . .	110kW @ 2500 RPM (ISO NET)
<b>Torque.</b>	. . . . .	420Nm @ 1400 RPM (ISO NET)
<b>Wheelbases</b>	. . . . .	Short . . . . .2525mm Medium . . . . .3400mm
<b>Nominal Max Body length</b>	. . . . .	Short . . . . .3460mm Medium . . . . .4860mm





# 616 IFS

## Engine & Driveline specifications

### ENGINE

Engine . . . . .	Hino N04C US
Max output (ISO Net) . . . . .	110kW (150 PS) at 2500 RPM
Max torque (ISO Net) . . . . .	420Nm (42.8 kgf/m) at 1400 RPM
Maximum engine speed . . . . .	3100 RPM
Type . . . . .	Diesel, four cycle, four-cylinder in line, overhead valve, water cooled
Combustion system . . . . .	Direct injection type
Bore & stroke . . . . .	104 x 118mm
Piston displacement . . . . .	4.009 litres
Fuel injection system . . . . .	Electronic control, common rail type
Air intake system . . . . .	Turbo-intercooled, stack-type air intake
Air cleaner . . . . .	Paper element
Fan clutch . . . . .	Equipped
Exhaust system . . . . .	Catalytic Convertor with Diesel Particulate Active Reduction System (DPR)
Exhaust outlet . . . . .	Horizontal
Emission control system . . . . .	EGR & DPR meeting ADR 80/03 using Euro 5 Also meets EEV emission levels

### CLUTCH

Clutch type . . . . .	Dry single plate, diaphragm type with damper springs
Facing outside diameter . . . . .	325mm
Facing lining area . . . . .	483 x 2cm <sup>2</sup>
Control . . . . .	Hydraulic with vacuum booster

### TRANSMISSION

<b>Manual.</b> . . . . .	M550
Type . . . . .	Five-speed overdrive manual

### BRAKES

Service brakes . . . . .	Hydraulic system with ventilated disc brakes front and rear
Control . . . . .	Vacuum servo with hydraulic assist & dual circuits
Front disc diameter . . . . .	296mm
Rear disc diameter . . . . .	281mm
Anti-lock system (ABS) . . . . .	Equipped
Vehicle Stability Control . . . . .	Equipped
Traction Control . . . . .	Equipped
Easy Start system . . . . .	Equipped
Exhaust brake . . . . .	Electric-vacuum actuator with valve in exhaust pipe
Park brake . . . . .	Rear of transmission

### PERFORMANCE & GEAR RATIOS

Engine RPM @ 100km/h . . . . .	2600
Maximum speed (km/h) . . . . .	120
Gradeability tan $\theta$ % @ GVM . . . . .	52.7
Final drive ratio . . . . .	4.625:1

#### M550

1st . . . . .	.4.981	4th . . . . .	.1.000
2nd . . . . .	.2.911	5th . . . . .	.0.738
3rd . . . . .	.1.556	Rev. . . . .	.4.625

### AXLE LOAD & TYRE LOAD LIMITS

Front axle . . . . .	2600kg
Tyres . . . . .	2180kg
Rear axle . . . . .	4400kg
Tyres . . . . .	4120kg
Front axle type . . . . .	Independent coil
Rear axle type . . . . .	SH12 full-floating, single reduction, single speed by Hypoid gears

### SUSPENSION

#### Front suspension

<b>Independent.</b> . . . . .	Double wishbone independent with coil springs, shock absorbers & stabiliser
-------------------------------	---

#### Rear suspension

<b>Leaf</b>	Semi-elliptic main and auxiliary tapered leafsprings with silencers and shock absorbers
-------------	---

Spring dimensions, span & width . . . . .	1310mm x 70mm
Auxiliary springs . . . . .	900mm x 70mm

### WHEEL & TYRES

Wheel type . . . . .	5-stud disc wheel
Wheel & rim size . . . . .	185/85R16 111/109 & 16x5.5K-113mm
Number of tyres . . . . .	Seven including spare
Spare tyre carrier . . . . .	Equipped

### ELECTRICAL

Type . . . . .	24 volt, negative earth
Batteries . . . . .	12V x 2, series connected
Alternator type . . . . .	Built-in rectifier and voltage regulator
Capacity . . . . .	24V – 80 Amp
Starter capacity . . . . .	24V, 4.5kW



# 616 IFS

## Cab equipment & Instrumentation

### CHASSIS FRAME

Type . . . . .	Ladder-shaped channel section side rails
Chassis width at rear . . . . .	700mm
Max. section (depth x flange x thickness) . . . . .	180 x 65 x 6.0mm
Tensile strength . . . . .	440N/mm <sup>2</sup>
Towing hooks. . . . .	Equipped at front and rear
Front bumper. . . . .	Painted to cabin colour

### CAB EXTERIOR

Type . . . . .	Forward control, all steel welded construction, torsion-bar tilt mechanism, fully trimmed
Windscreen wipers. . . . .	Electric, dual wipers, intermittent and 2-speed
Outside rear mirrors . . . . .	Remote control & heated
Radiator grille . . . . .	Painted same colour as cabin
Lamps . . . . .	Halogen headlamps, fog lamps

### CAB INTERIOR

Steering . . . . .	Telescopic tilt column with integral power steering
Windscreen glass . . . . .	Laminated glass
Seating capacity . . . . .	Three
Driver's seat . . . . .	2-way adjustable, urethane foam pads, high-back seat
Assistant's seat . . . . .	Fixed bench, urethane foam pads, high-back seat
Seat cover. . . . .	Fabric cover
<b>Seat belts</b>	
Driver's seat . . . . .	3-point type with ELR and pre-tensioner
Assistant's seat . . . . .	3-point type with ELR and pre-tensioner
Centre passenger's seat. . . . .	2-point type
Sun visors . . . . .	For driver and passenger
Ventilator . . . . .	Forced type by electric blower
Inside rear mirror . . . . .	One, flat type
Cigarette lighter (24 volt) . . . . .	Equipped
Audio . . . . .	DAB AM/FM radio with CD&DVD player & Bluetooth
Heater and defroster . . . . .	Equipped
Air conditioner . . . . .	Equipped
Remote door locking . . . . .	Equipped
Immobiliser . . . . .	Equipped
Power windows . . . . .	Equipped
SRS airbag . . . . .	Equipped for driver and left side passenger
Seat back console . . . . .	Equipped (centre)
Overhead consoles. . . . .	For driver and assistant
Cup holder. . . . .	Equipped

### POWER & TORQUE CHART (ISO Net) N04C US

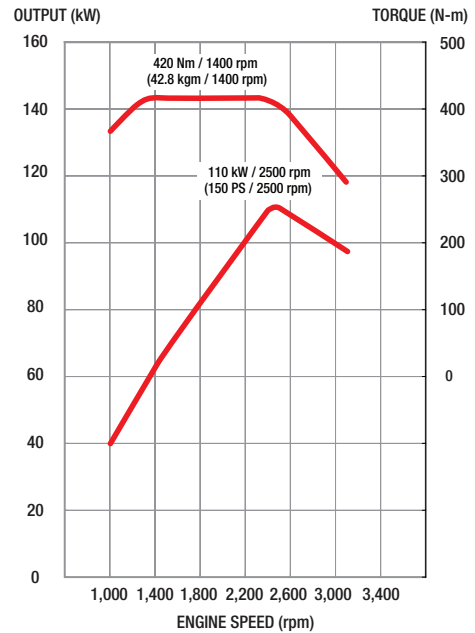

### INSTRUMENTS

- |  |  |
|--|--|
| <p><b>1. Meters and gauges</b></p> <ul style="list-style-type: none"> <li>km-kg system</li> <li>Engine tachometer</li> </ul> <p><b>2. Warning, pilot lamps and buzzers</b></p> <ul style="list-style-type: none"> <li>Turning signal &amp; hazard indicator lamp</li> <li>Exhaust brake indicator lamp</li> <li>Engine oil pressure warning lamp</li> <li>Battery charge warning lamp</li> <li>High beam indicator lamp</li> <li>Parking brake indicator lamp</li> <li>Engine malfunction indicator lamp</li> <li>Fuel level warning lamp</li> <li>Fuel filter water accumulating level warning lamp</li> <li>Brake fluid level warning lamp</li> <li>Back-up warning buzzer</li> <li>Cab-tilt warning lamp</li> <li>ABS system failure warning lamp</li> <li>SRS airbag system failure warning lamp</li> <li>Easy Start indicator lamp</li> </ul> | <p><b>3. Switches</b></p> <ul style="list-style-type: none"> <li>Lighting switch</li> <li>Wiper and washer switch</li> <li>Exhaust brake switch</li> <li>Easy Start switch</li> <li>Easy Start release timing adjuster switch</li> <li>Traction Control OFF</li> </ul> <p><b>4. Multi Information Display</b></p> <ul style="list-style-type: none"> <li>Fuel gauge</li> <li>Coolant temperature gauge</li> <li>DPR accumulation gauge</li> <li>Odometer</li> <li>2 trip meters</li> <li>Fuel consumption               <ul style="list-style-type: none"> <li>- Current</li> <li>- Average</li> </ul> </li> </ul> <p><b>5. Others</b></p> <ul style="list-style-type: none"> <li>One-key starting-stopping</li> <li>Horn button</li> <li>Remote door locking</li> </ul> |
|--|--|

### STEERING

Type . . . . .	Telescopic and tilt steering column with locking device. Rack & pinion with integral power steering.
Steering angle . . . . .	<b>Inside:</b> 39° <b>Outside:</b> 29°



# 616 IFS

## Dimensions

**300**  
S E R I E S

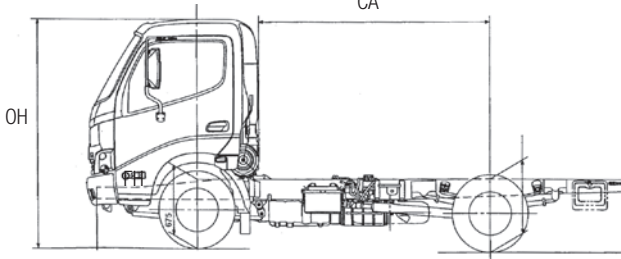
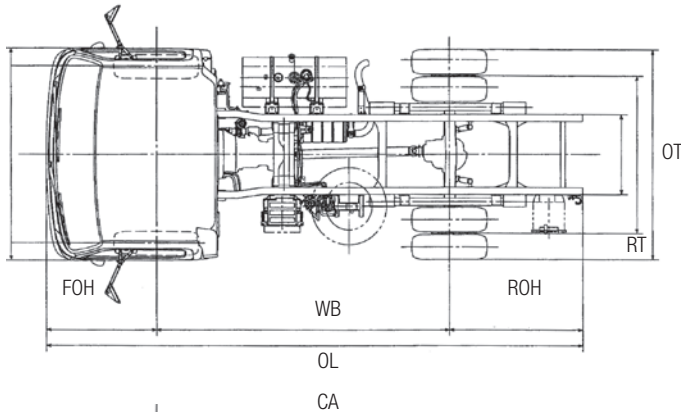
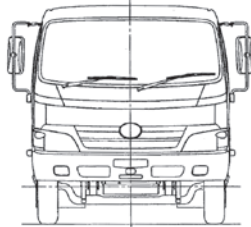

### DIMENSIONS – mm / Capacities

Model	616 Short IFS	616 Medium IFS
Product code	XZU605R- HKMMSQ3	XZU655R- HKMMSQ3
Wheelbase (WB)	2525	3400
Nominal Max Body Length	3460	4860
Overall tyre width (OT)	1845	1845
Overall length (OL)	4710	5965
Overall width (OW) CAB	1695	1695
Overall height (OH)	2100	2095
Front track	1400	1400
Rear track	1435	1435
Cab to axle centre (CA)	2025	2900
Front overhang (FOH)	980	980
Rear overhang (ROH)	1135	1555
Front chassis height	655	655
Rear chassis height	695	695
Road clearance	170	170
Turning circle - m (kerb-to-kerb)	9.6	12.4
Turning circle - m (wall-to-wall)	11.0	13.8
Fuel tank – lt.	80	100
<b>Indicative chassis mass – kg</b> (standard tools, 10 litres of fuel, without spare tyre)		
Total	1970	2025
Front	1365	1410
Rear	605	615
GVM*	5500	5500
GCM*	9000	9000

\*Std GVM = 4495 OPT 5500; Std GCM = 7995 OPT 9000

### GENUINE ACCESSORY OPTIONS

Bull bar	Roof scoop
Chrome wheel covers	Side skirts
GPS sat nav	Stoneguard
Rear vision camera (up to 3)	Sunvisor

**Please check with your dealer for price, availability & fitment for these options**

### WARRANTY

New vehicle warranty period

Light Duty Model	Axle configuration	Standard warranty (whichever comes first)	Cab corrosion perforation
<b>300 616 IFS</b>	4 x 2	<b>3 years or 100,000km</b>	<b>36 months</b>

Battery warranty – 12 months from date of delivery

Genuine parts or accessories warranty – 3 years unlimited kilometres when fitted by an authorised Hino dealer \*

\* For conditions, refer to the Hino Parts & Service warranty brochure

### DISCLAIMER

Important notice. Hino Trucks are distributed in Australia by Hino Motor Sales Australia Pty Ltd A.C.N. 064 989 724.

All efforts have been made to ensure the information contained in this brochure was correct at time of printing or uploading. Hino Motor Sales Australia Pty Ltd reserves the right to alter any details of the specifications & equipment without notice. Hino in so far as it is permitted by law to do so, shall not be liable in any way as a result of any reliance placed by any person on anything contained in this brochure. You should therefore check with your authorised Hino dealer at the time of ordering your motor vehicle to ensure that colour, specifications, equipment, design features & options are available for the vehicle you are ordering. Please note that some options may only be available in combination with others. Authorised Hino dealers will on request provide up to date information on all accessories, design features, prices & availability.

Date of issue - 01/10/11 616 IFS v3.1