

NEW

300
S E R I E S

716 Auto



* Illustration may contain items not standard to the model

**New ADR 80/03 Model
Wide Cab 4 x 2 Cab Chassis**

KEY FEATURES

- Dual SRS Airbags
- Disc Brakes
 - Front & Rear
 - ABS, VSC & TRC – all STD
- Energy Absorbing Steering Wheel
- ADR 80/03 Emission using Euro 5
- Also meet EEV emission levels
- Driver's suspension seat

KEY SPECIFICATIONS

GVM6500kg, optional 4495kg
GCM	7300kg
Engine	4.0-litre, Common Rail, Direct Injection, Turbocharged and Intercooled
Power.	110kW (150PS) @ 2500 RPM (ISO NET)
Torque	420Nm @ 1400 RPM (ISO NET)
Wheelbase.	Medium3430mm
Nominal Max Body length	Medium4840mm





716 Auto

Engine & Driveline specifications

ENGINE

Engine	Hino N04C US
Max output (ISO Net)	110kW (150 PS) @ 2500 RPM
Max torque (ISO Net)	420Nm (42.8 kgf/m) @ 1400 RPM
Maximum engine speed	3100 RPM
Type	Diesel, four cycle, four-cylinder in line, overhead valve, water cooled
Combustion system	Direct injection type
Bore & stroke	104 x 118mm
Piston displacement	4.009 litres
Fuel injection system	Electronic control, common rail type
Air intake system	Turbo-intercooled, front air intake
Air cleaner	Paper element
Fan clutch	Equipped
Exhaust system	Catalytic Convertor with Diesel Particulate Active Reduction System (DPR)
Exhaust outlet	Horizontal
Emission control system	EGR & DPR meeting ADR 80/03 using Euro 5 Also meets EEV emission levels

TRANSMISSION

Auto	A860E
Type	Automatic six speed with double overdrive

BRAKES

Service brakes	Hydraulic system with ventilated disc brakes front and rear
Control	Vacuum servo with hydraulic assist & dual circuits
Front disc diameter	287mm
Rear disc diameter	287mm
Anti-lock system (ABS)	Equipped
Vehicle Stability Control	Equipped
Traction Control	Equipped
Exhaust Brake	Electric-vacuum actuator with valve in exhaust pipe
Park Brake	Rear of transmission

PERFORMANCE & GEAR RATIOS

Engine RPM @ 100km/h	2160
Maximum speed (km/h)	138
Gradeability tan θ % @ GVM	60.0
Final drive ratio	4.875:1

A860E

1st3.743	5th0.773
2nd2.003	6th0.634
3rd1.343	Rev.3.697
4th1.000		

AXLE LOAD & TYRE LOAD LIMITS

Front axle	3100kg
Tyres	2570kg
Rear axle	5100kg
Tyres	4860kg
Front axle type	I Beam
Rear axle type	SH12 full-floating, single reduction, single speed by Hypoid gears

SUSPENSION

Front suspension

Leaf	Semi-elliptic taper leaf spring with shock absorbers and stabiliser
Spring dimensions, span & width	1250mm x 70mm

Rear suspension

Leaf	Semi-elliptic main and auxiliary tapered leafsprings with silencers and shock absorbers
Spring dimensions, span & width	1310mm x 70mm
Auxiliary springs	900mm x 70mm

WHEEL & TYRES

Wheel type	6-stud disc wheel
Wheel & rim size	205/85R16 117/115 16x5.5
Number of tyres	Seven including spare
Spare tyre carrier	Equipped

ELECTRICAL

Type	24 volt, negative earth
Batteries	12V x 2, series connected
Alternator type	Built-in rectifier and voltage regulator
Capacity	24V – 80 Amp
Starter capacity	24V, 4.5kW



716 Auto

Cab equipment & Instrumentation

CHASSIS FRAME

Type	Ladder-shaped channel section side rails
Chassis width at rear	750mm
Max. section (depth x flange x thickness)	192.8 x 65 x 5.9mm
Tensile strength	540N/mm ²
Towing hooks.	Equipped at front and rear
Front bumper.	Painted to cabin colour

CAB EXTERIOR

Type	Forward control, all steel welded construction, torsion-bar tilt mechanism, fully trimmed
Windscreen wipers.	Electric, dual wipers, intermittent and 2-speed
Outside rear mirrors	Remote control & heated
Radiator grille	Painted same colour as cabin
Lamps	Halogen headlamps, fog lamps

CAB INTERIOR

Steering	Telescopic tilt column with integral power steering
Windscreen glass	Laminated glass
Seating capacity	Three
Driver's seat	4-way adjustable, urethane foam pads, high-back seat, lumbar support & suspension base
Assistant's seat	Fixed bench, urethane foam pads, high-back seat
Seat cover	Fabric cover
Seat belts	
Driver's seat	3-point type with ELR and pre-tensioner
Assistant's seat	3-point type with ELR and pre-tensioner
Centre passenger's seat.	2-point type
Sun visors	For driver and passenger
Ventilator	Forced type by electric blower
Inside rear mirror	One, flat type
Cigarette lighter (24 volt)	Equipped
Audio	DAB AM/FM radio with CD/DVD player & Bluetooth
Heater and defroster	Equipped
Air conditioner	Equipped
Remote door locking	Equipped
Immobiliser	Equipped
Power windows	Equipped
SRS airbag	Equipped for driver & left side passenger
Seat back console	Equipped (centre)
Overhead consoles.	For driver and assistant
Cup holder.	Equipped

POWER & TORQUE CHART (ISO Net) N04C US

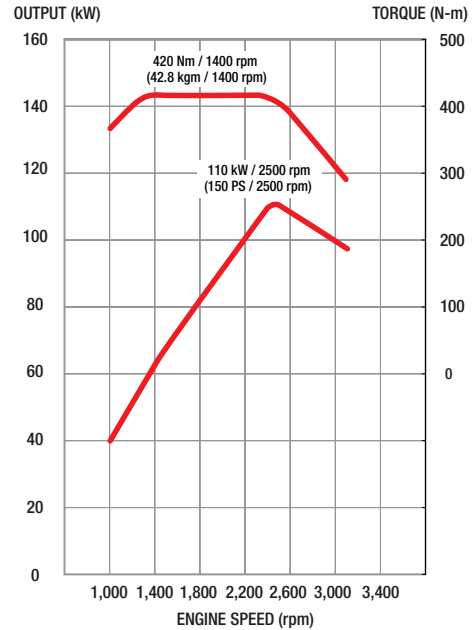

INSTRUMENTS

- Meters and gauges**
 - km-kg system
 - Engine tachometer
- Warning, pilot lamps and buzzers**
 - Turning signal & hazard indicator lamp
 - Exhaust brake indicator lamp
 - Engine oil pressure warning lamp
 - Battery charge warning lamp
 - High beam indicator lamp
 - Parking brake indicator lamp
 - Engine malfunction indicator lamp
 - Fuel level warning lamp
 - Fuel filter water accumulating level warning lamp
 - Brake fluid level warning lamp
 - Back-up warning buzzer
 - Cab-tilt warning lamp
 - ABS system failure warning lamp
 - SRS airbag system failure warning lamp
- Switches**
 - Lighting switch
 - Wiper and washer switch
 - Exhaust brake switch
 - Traction Control OFF
- Multi Information Display**
 - Fuel gauge
 - Coolant temperature gauge
 - DPR accumulation gauge
 - Odometer
 - 2 trip meters
 - Fuel consumption
 - Current
 - Average
- Others**
 - One-key starting-stopping
 - Horn button
 - Remote door locking

STEERING

Type	Telescopic and tilt steering column with locking device. Recirculating ball with integral power steering
Steering angle	Inside: 50° Outside: 36°



716 Auto Dimensions

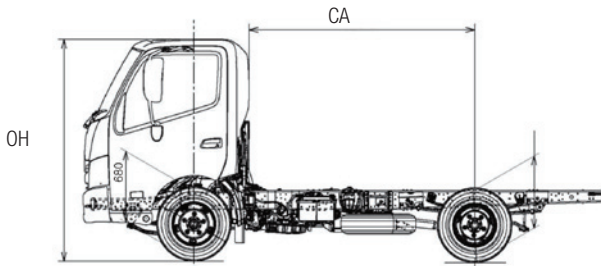
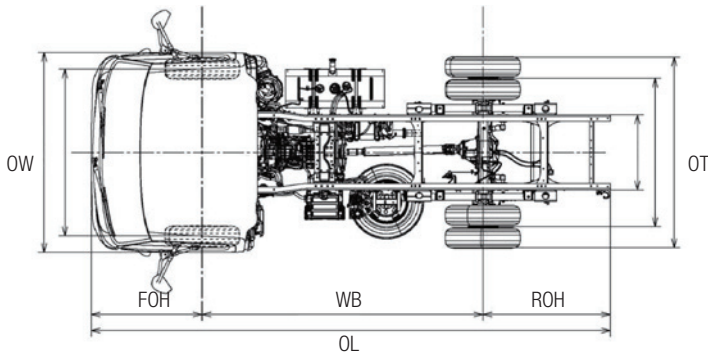

DIMENSIONS – mm / Capacities

Model	716 Medium Auto
Product code	XZU710R-HKTQSQ3
Wheelbase (WB)	3430
Nominal Max Body length	4840
Overall tyre width (OT)	1995
Overall length (OL)	6185
Overall width (OW)	1995
Overall height (OH)	2205
Front track	1665
Rear track	1520
Cab to axle centre (CA)	2870
Front overhang (FOH)	1110
Rear overhang (ROH)	1645
Front chassis height	695
Rear chassis height	760
Road clearance	180
Turning circle – m (kerb-to-kerb)	11.6
Turning circle – m (wall-to-wall)	13.0
Fuel tank - lt	170
Indicative chassis mass – kg (standard tools, 10 litres of fuel, without spare tyre)	
Total	2375
Front	1635
Rear	740
GVM*	6500
GCM	7300

*Std GVM = 6500 OPT 4995

GENUINE ACCESSORY OPTIONS

- | | |
|------------------------------|-------------|
| Bull bar | Roof scoop |
| Chrome wheel covers | Side skirts |
| GPS sat nav | Stoneguard |
| Rear vision camera (up to 3) | Sunvisor |

Please check with your dealer for price, availability & fitment for these options

WARRANTY

New vehicle warranty period

Light Duty Model	Axle configuration	Standard warranty (whichever comes first)	Cab corrosion perforation
300 716 Auto	4 x 2	3 years or 100,000km	36 months

Battery warranty – 12 months from date of delivery

Genuine parts or accessories warranty – 3 years unlimited kilometres when fitted by an authorised Hino dealer *

* For conditions, refer to the Hino Parts & Service warranty brochure

DISCLAIMER

Important notice. Hino Trucks are distributed in Australia by Hino Motor Sales Australia Pty Ltd A.C.N. 064 989 724.

All efforts have been made to ensure the information contained in this brochure was correct at time of printing or uploading. Hino Motor Sales Australia Pty Ltd reserves the right to alter any details of the specifications & equipment without notice. Hino in so far as it is permitted by law to do so, shall not be liable in any way as a result of any reliance placed by any person on anything contained in this brochure. You should therefore check with your authorised Hino dealer at the time of ordering your motor vehicle to ensure that colour, specifications, equipment, design features & options are available for the vehicle you are ordering. Please note that some options may only be available in combination with others. Authorised Hino dealers will on request provide up to date information on all accessories, design features, prices & availability.

Date of issue - 01/10/11 716 Auto v3.1