

NEW

300
SERIES

916 Hybrid



* Illustration may contain items not standard to the model

ADR 80/03 Model
Wide Cab 4 x 2 Cab Chassis

KEY FEATURES

- Dual SRS Airbags
- Easy Start – Take Off Assist
- Disc Brakes
 - Front & Rear
 - ABS, VSC & TRC – all STD
- Energy Absorbing Steering Wheel
- HID Headlamps with washers
- 5-Speed Automated Manual Transmission (AMT)
- ADR 80/03 Emission using EURO 5
- Also meets EEV emission levels
- Drivers suspension seat

KEY SPECIFICATIONS

GVM.7995kg, optional 8500kg
GCM.	11,500kg, optional 12,000kg
Engine.4.0-litre, Common Rail, Direct Injection, Turbocharged and Intercooled
Power	110kW @ 2500 RPM (ISO NET)
Torque.	420Nm @ 1400 RPM (ISO NET)
Wheelbases	Medium3430mm Long3870mm
Nominal Max Body length	Medium4840mm Long5550mm





916 Hybrid

Engine & Driveline specifications

DIESEL ENGINE

Engine	Hino N04C UR
Max output (ISO Net)	110kW (150 PS) at 2500 RPM
Max torque (ISO Net)	420Nm (42.8 kgf/m) at 1400 RPM
Maximum engine speed	3100 RPM
Type	Diesel, four cycle, four-cylinder in line, overhead valve, water cooled
Combustion system	Direct injection type
Bore & stroke	104 x 118mm
Piston displacement	4.009 litres
Fuel injection system	Electronic control, common rail type
Air intake system	Turbo-intercooled, stack-type air intake
Air cleaner	Paper element
Fan clutch	Equipped
Exhaust system	Catalytic Converter with Diesel Particulate Active Reduction System (DPR)
Exhaust outlet	Horizontal
Emission control system	EGR & DPR meeting ADR 80/03 using Euro 5 Also meets EEV emission levels

HYBRID DRIVE SYSTEM

Motor type	AC Synchronous motor
Rated voltage	300V
Max output	36kW
Max torque	333Nm
Idle stop	Equipped
Battery type	Nickel-metal hydride
Battery capacity	288V/6.5Ah

CLUTCH

Clutch type	Dry single plate, diaphragm type with damper springs
Facing outside diameter	300mm
Facing lining area	423 x 2cm ²
Control	Electronic with transmission

TRANSMISSION

Automated Manual	M550
Type	Five-speed overdrive AMT

BRAKES

Service brakes	Hydraulic system with ventilated disc brakes front and rear
Control	Vacuum servo with hydraulic assist & dual circuits
Front disc diameter	287mm
Rear disc diameter	287mm
Anti-lock system (ABS)	Equipped
Vehicle Stability Control	Equipped
Traction Control	Equipped
Easy Start system	Equipped
Exhaust brake	Electric-vacuum actuator with valve in exhaust pipe
Park brake	Rear of transmission

PERFORMANCE & GEAR RATIOS

Engine RPM @ 100km/h	2600
Maximum speed (km/h)	120
Gradeability tan θ % @ GVM	31.2
Final drive ratio	5.142:1

M550

1st4.981	4th1.000
2nd2.911	5th0.738
3rd1.556	Rev.4.625

AXLE LOAD & TYRE LOAD LIMITS

Front axle	3100kg
Tyres	3100kg
Rear axle	6200kg
Tyres	6000kg
Front axle type	I Beam
Rear axle type	SH13 full-floating, single reduction, single speed by Hypoid gears

SUSPENSION

Front suspension

Leaf	Semi-elliptic taper leaf spring with shock absorbers & stabiliser
Spring dimensions, span & width	1250mm x 70mm

Rear suspension

Leaf	Semi-elliptic main and auxiliary tapered leaf springs with silencers and shock absorbers
Spring dimensions, span & width	1310mm x 70mm
Auxiliary springs	900mm x 70mm

WHEEL & TYRES

Wheel type	6-stud disc wheel
Wheel & rim size	225/80R17.5 123/122
Number of tyres	Seven including spare
Spare tyre carrier	Equipped

ELECTRICAL (24 VOLT SYSTEM)

Type	24 volt, negative earth
Batteries	12V x 2, series connected
Recharge	80 Amp supplied by Hybrid System
Starter	Supplied by Hybrid System



916 Hybrid

Cab equipment & Instrumentation

CHASSIS FRAME

Type	Ladder-shaped channel section side rails
Chassis width at rear	750mm
Max. section (depth x flange x thickness)	192.8 x 65 x 5.9mm
Tensile strength	540N/mm ²
Towing hooks.	Equipped at front and rear
Front bumper.	Painted to cabin colour

CAB EXTERIOR

Type	Forward control, all steel welded construction, torsion-bar tilt mechanism, fully trimmed
Windscreen wipers.	Electric, dual wipers, intermittent and 2-speed
Outside rear mirrors	Remote control & heated
Radiator grille	Painted same colour as cabin
Lamps	HID headlamps with washer, fog lamps

CAB INTERIOR

Steering	Telescopic tilt column with integral power steering
Windscreen glass	Laminated glass
Seating capacity	Three
Driver's seat	4-way adjustable, urethane foam pads, high-back, lumbar support with suspension base
Assistant's seat	Fixed bench, urethane foam pads, high-back seat
Seat cover.	Fabric cover
Seat belts	
Driver's seat	3-point type with ELR and pre-tensioner
Assistant's seat	3-point type with ELR and pre-tensioner
Centre passenger's seat.	2-point type
Sun visors	For driver and passenger
Ventilator	Forced type by electric blower
Inside rear mirror	One, flat type
Cigarette lighter (24 volt)	Equipped
Audio	DAB AM/FM radio with CD&DVD player & Bluetooth
Heater and defroster	Equipped
Air conditioner	Equipped
Remote door locking	Equipped
Immobiliser	Equipped
Power windows	Equipped
SRS airbag	Equipped for driver and left side passenger
Seat back console	Equipped (centre)
Overhead consoles.	For driver and assistant
Cup holder.	Equipped

POWER & TORQUE CHART (ISO Net) N04C UR

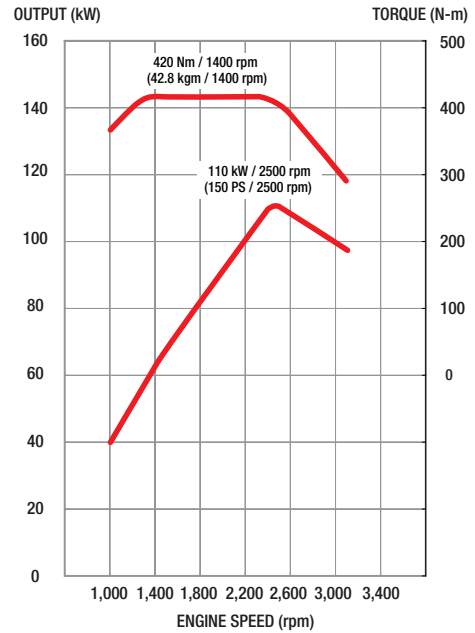

INSTRUMENTS

- | | |
|---|---|
| 1. Meters and gauges | AMT system lamp |
| km-kg system | |
| Engine tachometer | 3. Switches |
| Hybrid battery status | Lighting switch |
| 2. Warning, pilot lamps and buzzers | Wiper and washer switch |
| Turning signal & hazard indicator lamp | Exhaust brake switch |
| Exhaust brake indicator lamp | Easy Start switch |
| Engine oil pressure warning lamp | Easy Start release timing adjuster switch |
| Battery charge warning lamp | Traction Control OFF |
| High beam indicator lamp | 4. Multi Information Display |
| Parking brake indicator lamp | Fuel gauge |
| Engine malfunction indicator lamp | Coolant temperature gauge |
| Fuel level warning lamp | DPR accumulation gauge |
| Fuel filter water accumulating level warning lamp | Odometer |
| Brake fluid level warning lamp | 2 trip meters |
| Back-up warning buzzer | Fuel consumption |
| Cab-tilt warning lamp | - Current |
| ABS system failure warning lamp | - Average |
| SRS airbag system failure warning lamp | 5. Others |
| Easy Start indicator lamp | One-key starting-stopping |
| Hybrid system lamp | Horn button |
| | Remote door locking |

STEERING

Type	Telescopic and tilt steering column with locking device. Recirculating ball with integral power steering.
Steering angle	Inside: 44° Outside: 34°



916 Hybrid

Dimensions

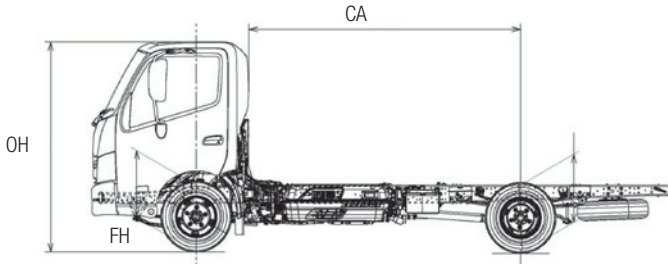
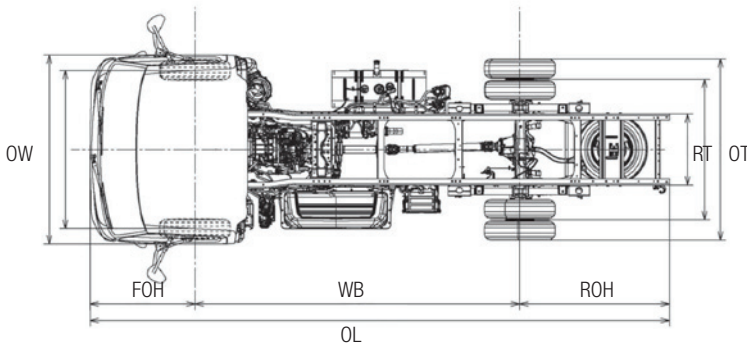

DIMENSIONS – mm / Capacities

Model	916 Medium Hybrid	916 Long Hybrid
Product code	XKU710R- HKUTSQ3	XKU720R- HKUTSQ3
Wheelbase (WB)	3430	3870
Nominal Max Body Length	4840	5550
Overall tyre width (OT)	2060	2060
Overall length (OL)	6185	6735
Overall width (OW) CAB	1995	1995
Overall height (OH)	2235	2235
Front track	1655	1655
Rear track	1590	1590
Cab to axle centre (CA)	2870	3310
Front overhang (FOH)	1110	1110
Rear overhang (ROH)	1645	1760
Front chassis height	725	725
Rear chassis height	815	815
Road clearance	200	200
Turning circle - m (kerb-to-kerb)	12.4	13.8
Turning circle - m (wall-to-wall)	13.8	15.2
Fuel tank – lt	100	100
Indicative chassis mass – kg (standard tools, 10 litres of fuel, without spare tyre)		
Total	2615	2630
Front	1705	1735
Rear	910	895
GVM*	8500	8500
GCM*	12,000	12,000
*Std GVM = 7995 OPT 8500; Std GCM = 11,500 OPT 12,000		

GENUINE ACCESSORY OPTIONS

Bull bar	Roof scoop
Chrome wheel covers	Side skirts
GPS sat nav	Stoneguard
Rear vision camera (up to 3)	Sunvisor

Please check with your dealer for price, availability & fitment for these options

WARRANTY

New vehicle warranty period

Light Duty Model	Axle configuration	Standard warranty (whichever comes first)	Cab corrosion perforation	Hybrid Nickel metal Hydride Battery (whichever comes first)
300 916 Hybrid	4 x 2	3 years or 100,000km	36 months	5 years or 160,000km

Battery warranty – 12 months from date of delivery

Genuine parts or accessories warranty – 3 years unlimited kilometres when fitted by an authorised Hino dealer *

* For conditions, refer to the Hino Parts & Service warranty brochure

DISCLAIMER

Important notice. Hino Trucks are distributed in Australia by Hino Motor Sales Australia Pty Ltd A.C.N. 064 989 724.

All efforts have been made to ensure the information contained in this brochure was correct at time of printing or uploading. Hino Motor Sales Australia Pty Ltd reserves the right to alter any details of the specifications & equipment without notice. Hino in so far as it is permitted by law to do so, shall not be liable in any way as a result of any reliance placed by any person on anything contained in this brochure. You should therefore check with your authorised Hino dealer at the time of ordering your motor vehicle to ensure that colour, specifications, equipment, design features & options are available for the vehicle you are ordering. Please note that some options may only be available in combination with others. Authorised Hino dealers will on request provide up to date information on all accessories, design features, prices & availability.

Date of issue - 01/10/11 916 Hybrid v3.1



www.hino.com.au