

NEW

300
SERIES

917



* Illustration may contain items not standard to the model

KEY FEATURES

- Dual SRS Airbags
- Easy Start – Take Off Assist
- Disc Brakes
 - Front & Rear
 - ABS, VSC & TRC – all STD
- Energy Absorbing Steering Wheel
- ADR 80/03 Emission using EURO 5
- Also meets EEV emission levels
- Driver's suspension seat

ADR 80/03 Model Wide Cab 4 x 2 Cab Chassis

KEY SPECIFICATIONS

GVM.7995kg, optional 8500kg
GCM.	11,500kg, optional 12,000kg
Engine.4.0-litre, Common Rail, Direct Injection, Turbocharged and Intercooled
Power	121kW @ 2500 RPM (ISO NET)
Torque.	464Nm @ 1400 RPM (ISO NET)
Wheelbases	Medium3430mm Long3870mm XLong. . . .4200mm
Nominal Max Body length	Medium4840mm Long5500mm XLong. . . .6080mm





917

Engine & Driveline specifications

ENGINE

Engine	Hino N04C UT
Max output (ISO Net)	121kW (165 PS) at 2500 RPM
Max torque (ISO Net)	464Nm (47.3 kgf/m) at 1400 RPM
Maximum engine speed	3100 RPM
Type	Diesel, four cycle, four-cylinder in line, overhead valve, water cooled
Combustion system	Direct injection type
Bore & stroke	104 x 118mm
Piston displacement	4.009 litres
Fuel injection system	Electronic control, common rail type
Air intake system	Turbo-intercooled, stack-type air intake
Air cleaner	Paper element
Fan clutch	Equipped
Exhaust system	Catalytic Converter with Diesel Particulate Active Reduction System (DPR)
Exhaust outlet	Horizontal
Emission control system	EGR & DPR meeting ADR 80/03 using Euro 5 Also meets EEV emission levels

CLUTCH

Clutch type	Dry single plate, diaphragm type with damper springs
Facing outside diameter	325mm
Facing lining area	483 x 2cm ²
Control	Hydraulic with vacuum booster

TRANSMISSION

Manual	MZZ6F
Type	Six-speed overdrive manual

BRAKES

Service brakes	Hydraulic system with ventilated disc brakes front and rear
Control	Vacuum servo with hydraulic assist & dual circuits
Front disc diameter	287mm
Rear disc diameter	287mm
Anti-lock system (ABS)	Equipped
Vehicle Stability Control	Equipped
Traction Control	Equipped
Easy Start system	Equipped
Exhaust brake	Electric-vacuum actuator with valve in exhaust pipe
Park brake	Rear of transmission

PERFORMANCE & GEAR RATIOS

Engine RPM @ 100km/h	2600
Maximum speed (km/h)	119
Gradeability tan θ % @ GVM	43.7
Final drive ratio	4.875:1

MZZ6F

1st6.369	5th1.000
2nd3.767	6th0.782
3rd1.966	Rev.6.369
4th1.355		

AXLE LOAD & TYRE LOAD LIMITS

Front axle	3100kg
Tyres	3100kg
Rear axle	6200kg
Tyres	6000kg
Front axle type	I Beam
Rear axle type	SH13 full-floating, single reduction, single speed by Hypoid gears

SUSPENSION

Front suspension

Leaf	Semi-elliptic taper leaf springs with shock absorbers & stabiliser
Spring dimensions, span & width	1250mm x 70mm

Rear suspension

Leaf	Semi-elliptic main and auxiliary tapered leafsprings with silencers and shock absorbers
Spring dimensions, span & width	1300mm x 70mm
Auxiliary springs	900mm x 70mm

WHEEL & TYRES

Wheel type	6-stud disc wheel
Wheel & rim size	225/80R17.5 123/122
Number of tyres	Seven including spare
Spare tyre carrier	Equipped

ELECTRICAL

Type	24 volt, negative earth
Batteries	12V x 2, series connected
Alternator type	Built-in rectifier and voltage regulator
Capacity	24V – 80 Amp
Starter capacity	24V, 4.5kW



917

Cab equipment & Instrumentation

CHASSIS FRAME

Type	Ladder-shaped channel section side rails
Chassis width at rear	750mm
Max. section (depth x flange x thickness)	192.8 x 65 x 5.9mm
Tensile strength	540N/mm ²
Towing hooks	Equipped at front and rear
Front bumper	Painted to cabin colour

CAB EXTERIOR

Type	Forward control, all steel welded construction, torsion-bar tilt mechanism, fully trimmed
Windscreen wipers	Electric, dual wipers, intermittent and 2-speed
Outside rear mirrors	Remote control & heated
Radiator grille	Painted same colour as cabin
Lamps	Halogen headlamps, fog lamps

CAB INTERIOR

Steering	Telescopic tilt column with integral power steering
Windscreen glass	Laminated glass
Seating capacity	Three
Driver's seat	4-way adjustable, urethane foam pads, high-back, lumbar support with suspension base
Assistant's seat	Fixed bench, urethane foam pads, high-back
Seat cover	Fabric cover
Seat belts	
Driver's seat	3-point type with ELR and pre-tensioner
Assistant's seat	3-point type with ELR and pre-tensioner
Centre passenger's seat	2-point type
Sun visors	For driver and passenger
Ventilator	Forced type by electric blower
Inside rear mirror	One, flat type
Cigarette lighter (24 volt)	Equipped
Audio	DAB AM/FM radio with CD&DVD player & Bluetooth
Heater and defroster	Equipped
Air conditioner	Equipped
Remote door locking	Equipped
Immobiliser	Equipped
Power windows	Equipped
SRS airbag	Equipped for driver and left side passenger
Seat back console	Equipped (centre)
Overhead consoles	For driver and assistant
Cup holder	Equipped

POWER & TORQUE CHART (ISO Net) N04C UT

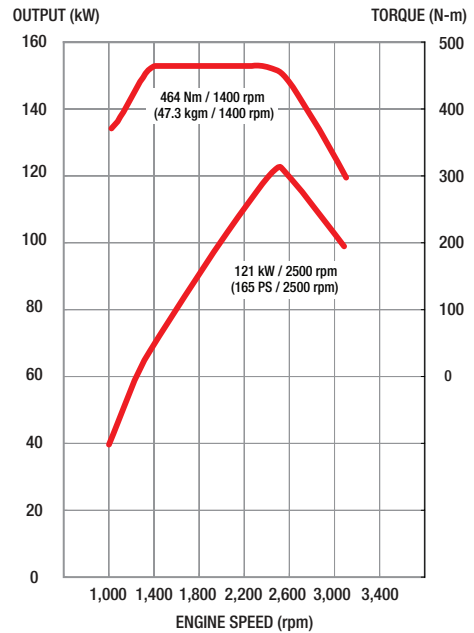

INSTRUMENTS

1. Meters and gauges

- km-kg system
- Engine tachometer

2. Warning, pilot lamps and buzzers

- Turning signal & hazard indicator lamp
- Exhaust brake indicator lamp
- Engine oil pressure warning lamp
- Battery charge warning lamp
- High beam indicator lamp
- Parking brake indicator lamp
- Engine malfunction indicator lamp
- Fuel level warning lamp
- Fuel filter water accumulating level warning lamp
- Brake fluid level warning lamp
- Back-up warning buzzer
- Cab-tilt warning lamp
- ABS system failure warning lamp
- SRS airbag system failure warning lamp
- Easy Start indicator lamp

3. Switches

- Lighting switch
- Wiper and washer switch
- Exhaust brake switch
- Easy Start switch
- Easy Start release timing adjuster switch
- Traction Control OFF

4. Multi Information Display

- Fuel gauge
- Coolant temperature gauge
- DPR accumulation gauge
- Odometer
- 2 trip meters
- Fuel consumption
 - Current
 - Average

5. Others

- One-key starting-stopping
- Horn button
- Remote door locking

STEERING

Type	Telescopic and tilt steering column with locking device. Recirculating ball with integral power steering.
Steering angle	Inside: 44° Outside: 34°



917

Dimensions

300
S E R I E S

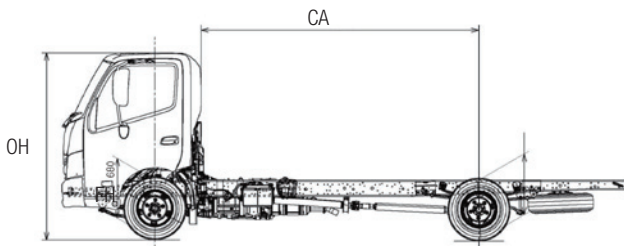
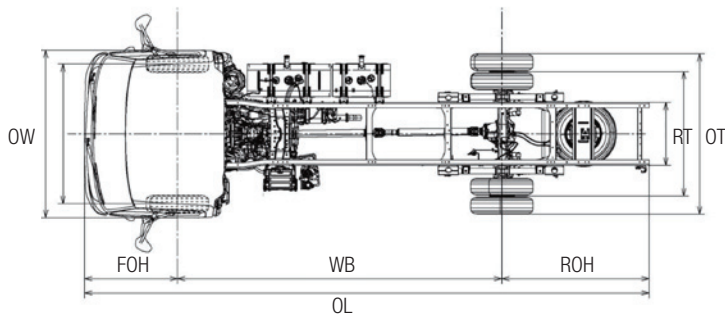

DIMENSIONS – mm / Capacities

Model	.917 Medium	917 Long	.917 XLong
Product code	XZU710R- HKFTTQ3	XZU720R- HKFTTQ3	XZU730R- HKFTTQ3
Wheelbase (WB)	3430	3870	4200
Nominal Max Body Length	4840	5500	6080
Overall tyre width (OT)	2060	2060	2060
Overall length (OL)	6185	6740	7285
Overall width (OW) CAB	1995	1995	1995
Overall height (OH)	2240	2235	2235
Front track	1655	1655	1655
Rear track	1590	1590	1590
Cab to axle centre (CA)	2870	3310	3640
Front overhang (FOH)	1110	1110	1110
Rear overhang (ROH)	1645	1760	1940
Front chassis height	725	725	725
Rear chassis height	815	815	815
Road clearance	200	200	200
Turning circle - m (kerb-to-kerb)	12.4	12.8	14.8
Turning circle - m (wall-to-wall)	13.8	14.2	16.2
Fuel tank – lt.	170	170	170
Indicative chassis mass – kg (standard tools, 10 litres of fuel, without spare tyre)			
Total	2460	2475	2510
Front	1640	1650	1665
Rear	820	825	845
GVM*	8500	8500	8500
GCM*	12,000	12,000	12,000

*Std GVM = 7995 OPT 8500; Std GCM = 11,500 OPT 12,000

GENUINE ACCESSORY OPTIONS

- | | |
|------------------------------|-------------|
| Bull bar | Roof scoop |
| Chrome wheel covers | Side skirts |
| GPS sat nav | Stoneguard |
| Rear vision camera (up to 3) | Sunvisor |

Please check with your dealer for price, availability & fitment for these options

WARRANTY

New vehicle warranty period

Light Duty Model	Axle configuration	Standard warranty (whichever comes first)	Cab corrosion perforation
300 917	4 x 2	3 years or 100,000km	36 months

Battery warranty – 12 months from date of delivery

Genuine parts or accessories warranty – 3 years unlimited kilometres when fitted by an authorised Hino dealer *

* For conditions, refer to the Hino Parts & Service warranty brochure

DISCLAIMER

Important notice. Hino Trucks are distributed in Australia by Hino Motor Sales Australia Pty Ltd A.C.N. 064 989 724.

All efforts have been made to ensure the information contained in this brochure was correct at time of printing or uploading. Hino Motor Sales Australia Pty Ltd reserves the right to alter any details of the specifications & equipment without notice. Hino in so far as it is permitted by law to do so, shall not be liable in any way as a result of any reliance placed by any person on anything contained in this brochure. You should therefore check with your authorised Hino dealer at the time of ordering your motor vehicle to ensure that colour, specifications, equipment, design features & options are available for the vehicle you are ordering. Please note that some options may only be available in combination with others. Authorised Hino dealers will on request provide up to date information on all accessories, design features, prices & availability.

Date of issue - 01/10/11 917 v3.1