



**ADR 80/03 Model**  
**4 x 2 Tipper**

\* Illustration may contain item not standard to the model

## KEY FEATURES

- Factory 3.6m & 4.0m Length Tipper Body
- Cruise Control
- ABS Brakes
- Easy Start – Take-off Assist
- Brake Lock System
- Drivers SRS Airbag
- Heated & Electrically Operated External Mirrors
- FUP (ADR 84/00 Complied)
- ISRI 6800 Driver seat with integrated Safety Belt

## KEY SPECIFICATIONS

<b>GVM.</b>	10,400kg
	Optional derate to 8,000kg
<b>GCM.</b>	16,000kg
<b>Power</b>	162kW @ 2400 RPM
<b>Torque.</b>	647Nm @ 1500 RPM
<b>Transmission</b>	Six-speed synchromesh
<b>Wheelbase</b>	3420mm (Compact – 3.6)
	3850mm (Short – 3.6 & 4.0)





# FC 1022 Tipper

## Engine & Driveline specifications

### ENGINE

Model	Hino J07E-TR
Max. output (ISO NET)	162kW (220 PS) at 2400 RPM
Max. output (JIS GROSS)	165kW (225 PS) at 2400 RPM
Max. torque (ISO NET)	647Nm (51kgf/m) at 1500 RPM
Max. torque (JIS GROSS)	667Nm (52kgf/m) at 1500 RPM
Max. engine speed	2400 RPM
Engine compliance	ADR 80/03
Type	Diesel, turbocharged & intercooled, five-cylinder in-line, overhead camshaft & water-cooled
Combustion system	Direct injection with EGR
Bore & stroke	112 x 130mm
Piston displacement	6.403L
Compression ratio	17.1:1
Engine oil capacity	11.7L
Coolant capacity	25L
Fuel injection pump	Electronic control common-rail type
Intake system	Stake-type air intake
Air cleaner	Dual paper elements
Air compressor type	Single cylinder, water-cooled
Bore & stroke	70 x 40mm
Fan clutch	Equipped
Exhaust	Horizontal outlet with DPR
Emission Control System	EGR & DPR meeting ADR 80/03 using EURO 5 Std

### CLUTCH

Model	CS-350 series
Type	Dry single plate with damper springs
Facing material	Moulded (non-asbestos)
Facing outside diameter	350mm
Control	Hydraulic with air booster

### TRANSMISSION & GEAR RATIOS

Model	LX06S Overdrive
Type	Six forward and one reverse speeds, synchromesh on 2nd to 6th
Control	Cable with power shift
Rear axle gear ratio	4.33:1

1st	.6.098	5th	.1.000
2nd	.3.858	6th	.0.761
3rd	.2.340	Rev.	.5.672
4th	.1.422		

### PERFORMANCE

Calculations based on 10.4 ton GVM, 9.5R17.5 tyre	
Engine RPM @ 100km/h	2125
Max theoretical speed (km/h)	112
Gradeability tan $\theta$ (%) @ GVM	39.9
Rear axle ratio	4.33:1

### BRAKES

Type	Hydraulic system with two leading shoes for front and rear acting on all wheels
Control	Air over hydraulic, dual circuits
Drum diameter x lining	
Width	Front: 320 x 110mm Rear: 320 x 145mm
Air dryer	Equipped
ABS	Equipped
ASR (Anti Slip Regulator)	Equipped
Brake lock system	Equipped
Parking brake	Mechanical, internal, expanding acting on transmission output shaft
Exhaust brake	Electric-pneumatic with valve in exhaust pipe
Easy Start	Equipped

### AXLE LOAD & TYPE

Axle load limit	Front axle	3600kg
	Rear axle	7000kg
Front axle type	LF366 series, Reversed Elliot I Beam	
Rear axle type	SH13 full-floating, single reduction, single-speed hypoid	

### SUSPENSION

Front suspension Type	Semi-elliptic tapered leaf springs with shock absorbers
Size	1300 span x 70mm width
Rear suspension Type	Semi-elliptic main & auxiliary leaf springs
Main springs	1300 span x 70mm width
Auxiliary springs	900mm span x 70mm width

### WHEELS & TYRES

Wheel type	Six-stud disc wheel (JIS type) PCD 222.25
Rim size	6.75 x 17.5 – offset 135mm
Tyre size	9.5R17.5-129/127
Number of tyres	Seven (including one spare tyre)
Spare tyre carrier	Equipped

### FUEL TANK

Capacity	200L
Fuel pre-filter & sedimenter	Equipped
Fuel tank cap key	Equipped



# FC 1022 Tipper

## Cab, Instrumentation & Chassis

### CAB DETAILS

Type . . . . .	Forward control, all-steel construction with torsion bar tilt mechanism
Drivers SRS Airbag . . . . .	Equipped with Pretensioner Seatbelt
Seating capacity . . . . .	Three
Driver's seat . . . . .	ISRI 6800 with urethane foam pads, high-back, lumbar support, multi adjustable, air suspended, with integrated safety belt
Side passenger's seat . . . . .	Urethane foam pads, high-back and reclining seat with fabric cover and under-tray
Centre passenger's seat . . . . .	Urethane foam pads & foldaway type with seat-back tray and fabric cover
Seat belt . . . . .	Three-point type on driver's & side passenger's seat, 2-point type on centre passenger's seat
Sun visor & overhead console . . . . .	For driver & passenger sides
Windshield wipers . . . . .	Electric, dual, intermittent and 2-speed
Ventilator . . . . .	Forced type by electric blower
Rear view mirrors . . . . .	External: Electric & heated, two flat type, two convex spotters
Cigarette lighter (24V) . . . . .	Equipped
Floor mat . . . . .	Vinyl type
Front air spoiler . . . . .	Equipped
Central locking & keyless entry . . . . .	Equipped with immobiliser
Heater & defroster . . . . .	Standard
Air conditioner . . . . .	Standard
Trim . . . . .	Full trim type (side, roof and back)
Cab pockets . . . . .	Equipped on both door sides
Power windows . . . . .	Equipped
Car audio . . . . .	DAB AM/FM radio with CD & DVD player and Bluetooth
Speakers . . . . .	Driver & passenger sides
Foot rest . . . . .	Equipped
Easy Start . . . . .	Equipped
Engine control link . . . . .	Equipped
Cup holder . . . . .	Equipped
Cruise Control . . . . .	Equipped

### ELECTRICAL

Type . . . . .	24V, negative earth
Batteries . . . . .	2 x12V, series connection. Capacity 65Ah at 20-hour rate
Alternator type . . . . .	Brushless with built-in rectifier and voltage regulator. Capacity 24V, 60A
Starter type . . . . .	24V, 4.5kW
Headlamps . . . . .	Halogen type including fog lamps
High/low beam . . . . .	Equipped
Fluorescent reading lamp . . . . .	Equipped
Electric horn . . . . .	Equipped

### POWER & TORQUE CHART (ISO Net) J07E-TR

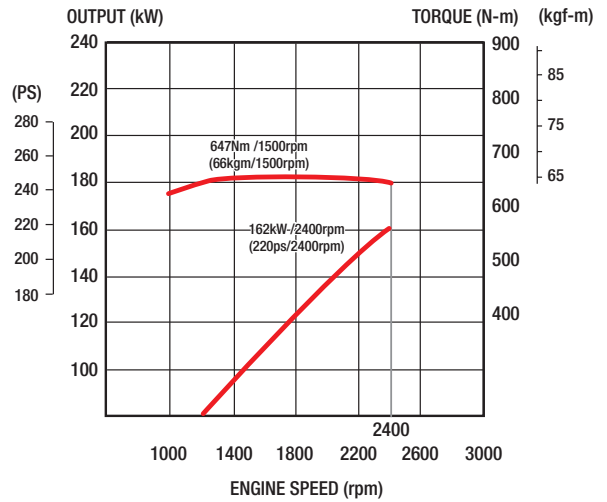

### INSTRUMENTS

- Meters & gauges**
    - Speedometer with trip meter
    - Odometer
    - Tachometer
    - Fuel gauge
    - Coolant temperature gauge
    - Air pressure gauge
  - Switches**
    - One-key starting-stopping
    - Lighting
    - Directional indicator, dimmer & passing
    - Wiper and washer
    - Hazard lamp
    - Exhaust brake
    - Map lamp
    - Fog lamp
    - Easy Start
    - DPR regeneration
    - ASR off
    - Mirror controls
  - Warning, pilot lamps & buzzers**
    - Oil pressure warning lamp & buzzer
- Air pressure warning lamp & buzzer  
 Engine over-run warning buzzer  
 Coolant level warning lamp & buzzer  
 Brake fluid level warning lamp & buzzer  
 Brake adjustment warning lamp & buzzer  
 High beam indicator lamp  
 Turn signal indicator lamp  
 Parking brake indicator lamp  
 Seat belt warning lamp & buzzer  
 Exhaust brake indicator lamp  
 Engine control system warning lamp  
 Hazard indicator lamp  
 Back-up warning buzzer
- Others**
    - Idle up control knob
    - Horn button
    - 12V electric source
    - PTO Engagement switch
    - Tipper control Raise / Hold & Lower lever

### STEERING

Type . . . . .	Telescopic & tilt steering column with locking device. Recirculating ball with Integral Power Steering
Gear ratio . . . . .	18.6:1
Steering angle . . . . .	<b>Inside:</b> 50-53° <b>Outside:</b> 39°

### CHASSIS FRAME / TIPPER PLATING

Type . . . . .	Ladder-shaped channel-section side rails
Rear chassis width . . . . .	820mm
Max. section (depth x flange x thickness) . . . . .	229.4 x 78 x 5.7mm (Compact) 228.4 x 73 x 5.2 (Short 3.6 & 4.0)
Tensile strength . . . . .	540N/mm <sup>2</sup> {55kgf/mm <sup>2</sup> }
Hooks . . . . .	Equipped for front & rear
Steel plate deck thickness . . . . .	6.0mm
Side, front & tailgate . . . . .	3.2mm
Factory FUP . . . . .	Equipped



# FC 1022 Tipper

## Dimensions

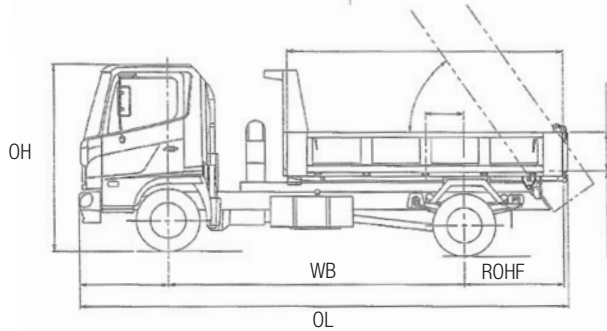
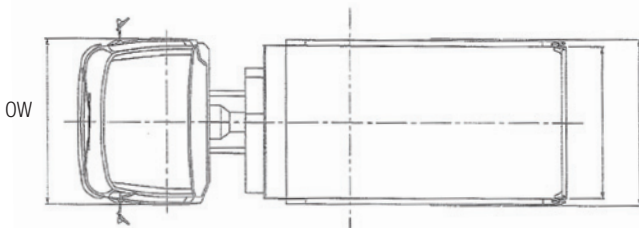
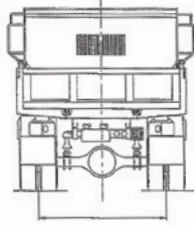

### DIMENSIONS - mm / Capacities

<b>Model</b>	Hino FC 1022	Compact 3.6	Short 3.6	Short 4.0
<b>Production code</b>	FC7JEMM-ANU D	FC7JEMA-ANU D	FC7JGMA-ANU D	FC7JGMA-ANU 4.0 D
<b>Wheelbase (WB)</b>	3420	3850	3850	3850
<b>Overall length (OL)</b>	5900	6330	6660	6660
<b>Overall width (OW)</b>	2190	2190	2250	2250
<b>Overall height (OH)</b>	2450	2450	2450	2450
<b>Inside length</b>	3600	3600	4000	4000
<b>Inside width</b>	2000	2000	2060	2060
<b>Road clearance (at diff. case) (RC)</b>	220	220	220	220
<b>Deck height</b>	1100	1100	1100	1100
<b>Front track (FT)</b>	1770	1770	1770	1770
<b>Rear track (RT)</b>	1660	1660	1660	1660
<b>Turning circle kerb to kerb</b>	11,200	12,400	12,400	12,400
<b>Turning circle wall to wall</b>	12,600	13,800	13,800	13,800
<b>Tipper volume</b>	3.6m <sup>3</sup>	3.6m <sup>3</sup>	3.5m <sup>3</sup>	3.5m <sup>3</sup>
<b>Tipping angle</b>	55'	55'	50'	50'
<b>Internal measurements (L x W x H)</b>	3600 x 2000 x 510	3600 x 2000 x 510	4000 x 2060 x 430	4000 x 2060 x 430
<b>Two way gate hinging top &amp; bottom</b>	Equipped	Equipped	N/A	N/A
<b>Two way gate hinging top &amp; side</b>	N/A	N/A	Equipped	Equipped
<b>Body Lock</b>	N/A	N/A	Fitted	Fitted
<b>Chassis mass – kg</b> (standard tools, 10 litres of fuel, without spare tyre)				
<b>Total</b>	4595	4650	4735	4735
<b>Front</b>	2436	2298	2406	2406
<b>Rear</b>	2159	2352	2329	2329
<b>GVM</b>	10,400	10,400	10,400	10,400
<b>GCM</b>	16,000	16,000	16,000	16,000

\*GVM can be derated to 8,000

### GENUINE ACCESSORY OPTIONS

Bull bar	Stoneguard
Chrome wheel covers	Sunvisor
Sat Nav	Timber dash panel
Rear vision camera (up to 3)	Tarp
Roof scoop	Engine driven PTO 1:108 step-up
Side skirts	

Please check with your dealer for price, availability & fitment for these options

### WARRANTY

New vehicle warranty period

Medium Duty Model	Axle configuration	Standard warranty (whichever comes first)	Cab corrosion perforation
500 FC 1022 Tipper	4 x 2	3 years or 150,000km	36 months

Battery warranty – 12 months from date of delivery

Genuine parts or accessories warranty – 3 years unlimited kilometres when fitted by an authorised Hino dealer \*

\* For conditions, refer to the Hino Parts & Service warranty brochure

### DISCLAIMER

Important notice. Hino Trucks are distributed in Australia by Hino Motor Sales Australia Pty Ltd A.C.N. 064 989 724.

All efforts have been made to ensure the information contained in this brochure was correct at time of printing or uploading. Hino Motor Sales Australia Pty Ltd reserves the right to alter any details of the specifications and equipment without notice. Hino in so far as it is permitted by law to do so, shall not be liable in any way as a result of any reliance placed by any person on anything contained in this brochure. You should therefore check with your authorised Hino dealer at the time of ordering your motor vehicle to ensure that colour, specifications, equipment, design features and options are available for the vehicle you are ordering. Please note that some options may only be available in combination with others. Authorised Hino dealers will on request provide up to date information on all accessories, design features, prices and availability.