



700
S E R I E S

FS 2844
FS 2844 Air



ADR 80/03 Model
6 x 4 Truck Chassis

* Illustration may contain item not standard to the model

KEY FEATURES

- ECE R29 Cab Strength Compliance
- Heated & Electrically Operated External Mirrors
- Cruise Control
- Integrated Factory FUPS
- Optional Air Rear Suspension
- ISRI 6860 Drivers Seat with Integrated Safety Belt

KEY SPECIFICATIONS

GVM	28,300kg
GCM	55,000kg
Power	321kW @ 1800 RPM
Torque	2059Nm @ 1100 RPM
TransmissionRTLO 16918B
Wheelbase	4305mm





FS 2844 FS 2844 Air

Engine, Driveline & Chassis specifications

ENGINE

Model	Hino E13C WB
Max. output (ISO NET)	321kW (437 PS) at 1800 RPM
Max. output (JIS GROSS)	329kW (447 PS) at 1800 RPM
Max. torque (ISO NET)	2059Nm (210kgf/m) at 1100 RPM
Max. torque (JIS GROSS)	2099Nm (214kgf/m) at 1100 RPM
Max. engine speed	1900rpm
Engine compliance	ADR 80/03
Type	Diesel, turbo charged & inter-cooled, 6 cylinder in-line, overhead camshaft
Combustion system	Direct injection type with Cooled-EGR
Bore & stroke	137 x 146mm
Piston displacement	12.913L
Compression ratio	17.0:1
Engine oil capacity	37.0L
Engine coolant capacity	27.4L
Fuel injection pump	Electronic control common rail
Governor	Electric
Air cleaner	Dual paper elements
Air compressor	Single cylinder, water cooled
Bore & stroke	95 x 70mm
Exhaust	Horizontal outlet with SCR
Emission Control System	EGR & SCR meeting ADR 80/03 using Euro 5 STD

CLUTCH

Model	Hino CR-380
Type	Dry twin plate with damper springs
Control	Hydraulic with air booster
Facing material	Ceramic
Facing diameter	387mm

TRANSMISSION

Model	RTLO 16918B
Type	Eaton 18 forward & 4 reverse speeds, double overdrive, constantmesh 1st-18th
Control	Mechanical
Final drive ratio	4.555:1

1st	14.402	12th	1.952
2nd	12.287	13th	1.617
3rd	8.561	14th	1.379
4th	7.303	15th	1.172
5th	6.048	16th	1.000
6th	5.160	17th	0.855
7th	4.384	18th	0.730
8th	3.740	Rev.	15.057
9th	3.201	Rev.	12.845
10th	2.731	Rev.	4.025
11th	2.288	Rev.	3.434

PERFORMANCE

Engine RPM @ 100km/h	1745
Max theoretical speed (km/h)	108
Vehicle electronically speed limited to 100km/h	
Gradeability Tan θ (%) @ GCM	49.9

BRAKES

Type	Full air, dual circuit, "S" cam type, leading & trailing shoes for front & rear with auto slack adjuster
Size	Front Drum 406.4 x 152mm Rear Drum 410.4 x 216mm
Air drier	Equipped
ABS	Equipped
Trailer brake control	Hand control on dash
Park brake	Spring brake acting on 1st & 2nd axle
Engine retarder	Engine compression brake equipped

AXLE LOAD & TYPE

Axle load limit	Front axle 7500kg Rear axle 21,800kg
Front axle type	MF781 series, Reversed Elliot, section I-Beam
Rear axle type	THD18 tandem axle, dual drive with inter-axle differential lock, full-floating single reduction, single-speed by hypoid
Rear rear axle	Cross lock fitted

SUSPENSION

Front suspension Type	Semi-elliptic tapered leaf springs with shock absorbers & stabiliser
Size	1700 x 90mm
Rear suspension Type FS 2844	Semi-elliptic leaf V Rod with shock absorber & stabiliser
Size	1350 x 80mm
Capacity	21,800kg
Rear suspension Type FS 2844 Air	Hendrickson HAS 460 airbag suspension with shock absorbers
Capacity	21,000kg

WHEELS & TYRES

Wheel type	10 stud disc wheels (ISO 335 PCD)
Rim size	22.5 x 8.25- offset 165mm
Tyre size	Front: 295/80R22.5 152/148 Rear: 11R22.5 148/145
Number of tyres	11 (including spare)
Tools included	Wheelbrace and jack
Spare tyre carrier	Equipped

FUEL TANK

Type	Square aluminium
Volume	400L
Fuel pre-filter & sedimenter	Equipped
Locking fuel cap	Equipped
Ad Blue Tank Capacity	28L



FS 2844 FS 2844 Air

Cab equipment & Instrumentation

CAB DETAILS

Type	Forward control, all steel welded construction, full-floating air-suspension cab with electrical tilting mechanism
ECER29 Cab strength	Compliant
Driver SRS Airbag	Equipped
Seating capacity	3
Driver's seat	ISRI 6860 Urethane foam pads, high-back, lumbar support, Multi adjustable, air suspended, with integrated Safety Belt
Passenger seat	Urethane foam pads, high back & reclining seat with fabric cover
Centre console	Equipped
Seat belts	3-point type on driver's & side passenger seats
Rear view mirrors	External electric & heated, two flat type & two-heated convex spotters
Windshield wipers	Electric, triple-arm, with intermittent & 2 speed control
Sun visor & overhead console	Equipped
Centre overhead console	Equipped
Cigarette lighter (24 volt)	Equipped
Ventilator	Forced type with electric blower
Heater & defroster	Equipped
Air conditioner	Equipped
Sleeper berth	Single
Audio	DAB+ AM/FM radio/CD & DVD player with Blue Tooth
Speakers	Driver, passenger & centre
Floor mat	Vinyl mat
Front air spoiler	Equipped
Cab step	Equipped
Trim	Full trim type / side roof back
Electric power windows	Both sides
Electric door lock	Remote control keyless entry
Cab pockets	Both door sides & passenger seat
Electrical converter	12V (harness type)
Cruise Control	Equipped

ELECTRICAL

Type	24 volts, negative earth
Batteries	12V x 2 series connection
Capacity	150Ah at 20 hour rate
Alternator	Brushless type 24V, 90A with built-in rectifier & voltage regulator
Starter	Pinion shift, capacity 24V, 6.0kW
Lamps	Headlamps, fog lamps, cornering, side marker, licence plate, stop/tail, back up, indicators & hazard, end outline marker, room lamp (fluorescent lamp), map lamp

POWER & TORQUE CHART (ISO NET) E13C WB

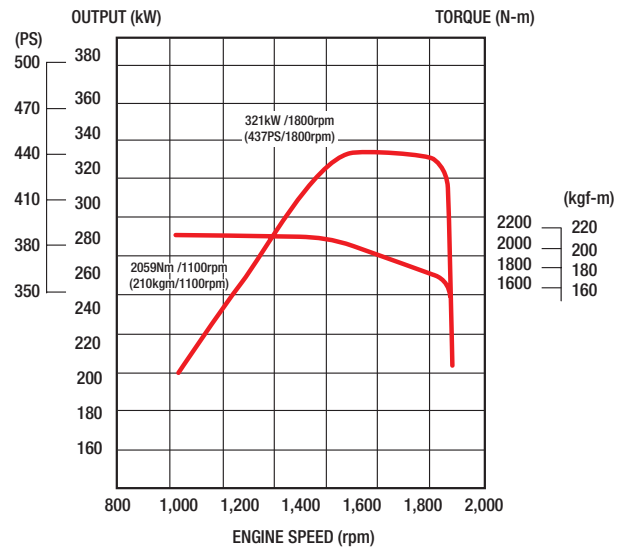

INSTRUMENTS

- Meters and gauges**
 - Speedometer with trip meter
 - Odometer
 - Fuel gauge
 - Tachometer
 - Coolant temperature gauge
 - Air pressure gauge x 2
- Switches**
 - Lights
 - Indicators, dimmer & passing
 - Wiper & washer
 - Hazard lamp
 - Fog lamp
 - Room lamp
 - Warning lamp check
 - Map lamp
 - Differential lock
 - Rear rear differential cross lock
 - Mirror heating
 - Economy running
 - Cruise Control
- Warning, pilot lamps and buzzers**
 - Engine oil pressure warning lamp & buzzer
 - Air pressure warning lamp & buzzer
 - Beam indicator lamp
 - Turn signal indicator lamp
 - Parking brake indicator lamp
 - Coolant level warning lamp & buzzer
 - Differential lock indicator lamp
 - Engine over-run warning buzzer
 - Fuel level warning lamp
 - Battery charging indicator lamp
 - Fuel filter water level warning lamp
 - Transmission splitter range
 - Speed limiter warning indicator lamp
 - ABS warning lamp
 - Trailer brake indicator lamp
- Others**
 - One key starting-stopping
 - Horn button
 - Idle up control knob

STEERING

Steering column	Telescopic & tilt with locking device
Steering box	Recirculating ball with Integral Power Steering
Gear ratio	24.1 - 23.8 - 1
Steering angle	Inside: 48-50° Outside: 39°

CHASSIS FRAME

Type	Ladder-shaped channel section side rails
Rear chassis width	840mm
Size	Main: 300 x 88 x 8.0mm Inner: 275 x 80 x 7.0mm
Tensile strength	Main: 620N/mm ² {63kgf/mm ² } Inner: 540N/mm ² {55kgf/mm ² } (FS 2844 only)
Hook	Equipped for front
Front Underrun Protection	Equipped



FS 2844
FS 2844 Air

700
S E R I E S

Dimensions

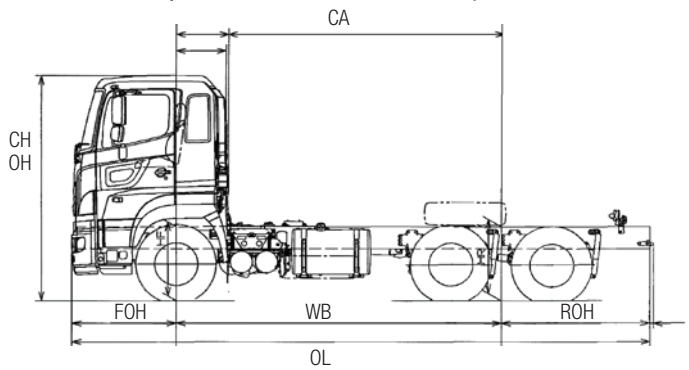
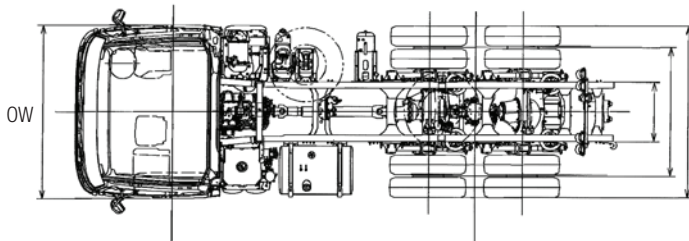

(Drawing of FS2844 Air)

DIMENSIONS – mm / Capacities

Model	FS 2844	FS 2844 Air
Product code	FS1ELLA-NAZ	FS1ELLG-NAZ
Wheelbase (WB)	4305	4305
Overall length (OL)	7645	7645
Overall width (OW)	2490	2490
Overall height (OH)	3000	3000
Cab to rear axle centre (CA)	3595	3595
Front overhang (FOH)	1380	1380
Rear overhang (ROH)	1960	1960
Front chassis height	995	995
Rear chassis height	1085	1040
Road clearance (at diff. case)	215	210
Front track	2050	2050
Rear track	1820	1840
Turning circle (kerb to kerb)	15,800	16,000
Turning circle (wall to wall)	17,520	17,560
Chassis mass – kg (standard tools, 10 litres of fuel, without spare tyre)		
Total	8965	8250
Front	4860	4655
Rear	4105	3595
GVM	28,300	28,300
GCM	55,000	55,000

GENUINE ACCESSORY OPTIONS

Bull bar	Side skirts
Chrome wheel covers	Step cover kit
Sat Nav	Stoneguard
Rear vision camera (up to 3)	Woodgrain dash panel
Roof spoiler	

Please check with your dealer for price, availability & fitment for these options

WARRANTIES

New vehicle warranty period

Heavy Duty Model	Axle configuration	Standard warranty (whichever comes first)	Engine component warranty (whichever comes first)	Cab corrosion perforation
700 FS 2844	6 x 4	3 years or 500,000km	60 month or 750,000km	36 months

Battery warranty – 12 months from date of delivery. Engine component warranty covers, crankshaft, cylinder block and head castings. Genuine parts or accessories warranty – 3 years unlimited kilometres when fitted by an authorised Hino dealer. For conditions, refer to the Hino Parts & Service warranty brochure.

DISCLAIMER

Important notice. Hino Trucks are distributed in Australia by Hino Motor Sales Australia Pty Ltd A.C.N. 064 989 724.

All efforts have been made to ensure the information contained in this brochure was correct at time of printing or uploading. Hino Motor Sales Australia Pty Ltd reserves the right to alter any details of the specifications and equipment without notice. Hino in so far as it is permitted by law to do so, shall not be liable in any way as a result of any reliance placed by any person on anything contained in this brochure. You should therefore check with your authorised Hino dealer at the time of ordering your motor vehicle to ensure that colour, specifications, equipment, design features and options are available for the vehicle you are ordering. Please note that some options may only be available in combination with others. Authorised Hino dealers will on request provide up to date information on all accessories, design features, prices and availability.

Date of issue - 01/01/12 FS 2844 v3.2