



ADR 80/03 Model
6 x 4 Truck Chassis

* Illustration may contain item not standard to the model

KEY FEATURES

- Automated Manual Transmission
- Transmission Intarder & Jacob Type Engine Brake
- ECE R29 Cab Strength Compliance
- Integrated FUP
- Heated & Electrically Operated External Mirrors
- Cruise Control
- HID Headlamps
- ISRI 6860 Drivers Seat with integrated Safety belt

KEY SPECIFICATIONS

GVM	28,300kg
GCM	72,000kg
Power	353kW @ 1800 RPM
Torque	2157Nm @ 1100 RPM
Transmission	ZF AS TRONIC
Wheelbase	4005mm





SS 2848 Pro-Shift 16 Air

Engine, Driveline & Chassis specifications

ENGINE

Model	Hino E13C VG
Max. output (ISO NET)	353kW (480 PS) at 1800rpm
Max. output (JIS GROSS)	360kW (490 PS) at 1800rpm
Max. torque (ISO NET)	2157Nm at 1100rpm
Max. torque (JIS GROSS)	2197Nm at 1100rpm
Max. engine speed.	1900rpm
Engine compliance.	ADR 80/03
Type	Diesel, turbo charged & inter-cooled, 6 cylinder in-line, overhead camshaft
Combustion system	Direct injection type with Cooled-EGR
Bore & stroke	137 x 146mm
Piston displacement	12.913L
Compression ratio	17.0:1
Engine oil capacity	37.0L
Engine coolant capacity	27.4L
Fuel injection pump	Electronic control common rail
Governor	Electric
Air cleaner.	Dual paper elements
Air compressor	Single cylinder, water cooled
Bore & stroke	95 x 70mm
Exhaust.	Horizontal outlet with SCR
Emission Control System	EGR & SCR meeting ADR 80/03 using Euro 5 STD

CLUTCH

Model	CS-430 Series
Type	Dry single plate with damper springs
Control	Automated & Auto adjusting
Facing material	Moulded
Facing diameter.	430mm

TRANSMISSION

Model	ZF AS TRONIC
Type	ZF AMT 16 Forward, 2 Reverse
Code	16 AS 2631 TO with Intarder
Control	Electronic
Final drive ratio	3.9:1

	Low	High
1st	14.120	11.677
2nd	9.539	7.889
3rd	6.521	5.393
4th	4.565	3.776
5th	3.093	2.558
6th	2.089	1.728
7th	1.428	1.181
8th	1.000	0.827
Rev.	13.704	10.812

PERFORMANCE

Engine RPM @ 100km/h	1693
Max theoretical speed (km/h)	112
Vehicle electronically speed limited to 100km/h	
Gradeability Tan θ (%) @ GCM	31

BRAKES

Type	Full air, dual circuit, "S" cam type, leading & trailing shoes for front & rear with auto slack adjuster
Size	Front Drum 406.4 x 152mm Rear Drum. 410.4 x 216mm
Air drier.	Equipped
ABS	Equipped
Trailer brake control	Hand control on dash
Park brake.	Spring brake acting on 1st & 2nd axle
Engine brake	Engine compression brake equipped
Transmission brake	ZF Intarder

AXLE LOAD & TYPE

Axle load limit	Front axle 7500kg Rear axle 21,000kg
Front axle type	MF781 series, Reversed Elliot, section I-Beam
Rear axle type	THD18 tandem axle, dual drive with inter-axle differential lock, full-floating single reduction, single-speed by hypoid
Rear rear axle	Cross lock fitted

SUSPENSION

Front suspension Type	Semi-elliptic tapered leaf springs with shock absorbers & stabiliser
Size	1700 x 90mm
Rear suspension Type	Hendrickson HAS 460 airbag suspension with shock absorbers and Dump Valve
Capacity	21,000kg

WHEELS & TYRES

Wheel type	10 stud disc wheels (ISO 335 PCD)
Rim size	22.5 x 8.25- offset 165mm
Tyre size	Front: 295/80R22.5 152/148 Rear: 11R22.5 148/145
Number of tyres.	11 (including spare)
Tools included	Wheelbrace and jack

FUEL TANK

Type	Square aluminium
Volume	460L & 250L
Fuel pre-filter & sedimenter	Equipped
Locking fuel cap	Equipped
Ad Blue tank capacity.	56L



SS 2848 Pro-Shift 16 Air

Cab equipment & Instrumentation

CAB DETAILS

Type	Forward control, all steel welded construction, full-floating air-suspension cab with electrical tilting mechanism
ECER29 Cab strength.	Compliant
Driver SRS Airbag	Equipped
Front Underrun Protection	Equipped
Seating capacity	2 optional 3
Driver's seat	ISRI 6860 Urethane foam pads, high-back, lumbar support, Multi adjustable, air suspended, with integrated Safety Belt
Passenger seat	Urethane foam pads, high back & reclining seat with fabric cover
Centre console	Equipped
Seat belts	3-point type on driver's & side passenger seats
Rear view mirrors	2 external electrically controlled, flat type mirrors with heaters and spotters
Windshield wipers	Electric, triple-arm, with intermittent & 2 speed control
Sun visor & overhead console.	Equipped
Centre overhead console	Equipped
Cigarette lighter (24 volt)	Equipped
Ventilator	Forced type with electric blower
Heater & defroster	Equipped
Air conditioner	Equipped
Sleeper berth.	Single, with blackout curtains
Audio	DAB+ AM/FM radio/CD & DVD player with Blue Tooth
Speakers	Driver, passenger & centre
Floor mat	Vinyl mat
Front air spoiler.	Equipped
Cab step	Equipped
Trim	Full trim type / side roof back
Electric power windows	Both sides
Electric door lock	Remote control keyless entry
Cab pockets	Both door sides & passenger seat
Electrical converter.	12V (harness type)
Cruise Control	Equipped

ELECTRICAL

Type	24 volts, negative earth
Batteries	12V x 2 series connection
Capacity	150Ah at 20 hour rate
Alternator	Brushless type 24V, 90A with built-in rectifier & voltage regulator
Starter	24V, 6.0kW
Lamps	Gas discharge (HID) headlamps, fog lamps, cornering lamps, room lamp (fluorescent lamp), map lamp

POWER & TORQUE CHART (ISO NET) E13C VG

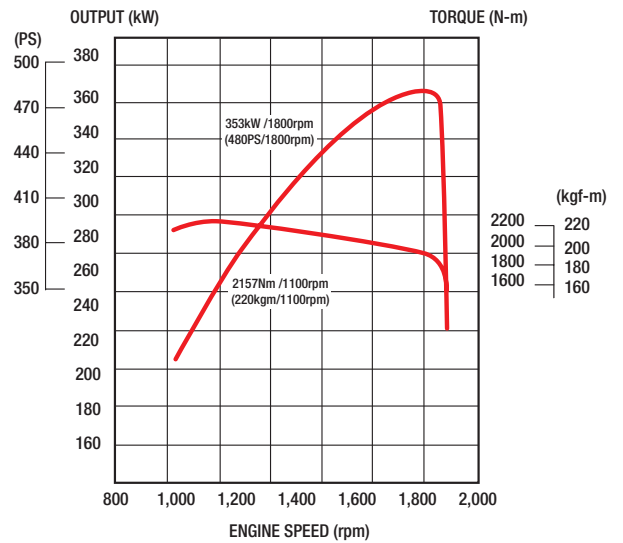

INSTRUMENTS

1. Meters and gauges

- Speedometer with trip meter
- Odometer
- Fuel gauge
- Tachometer
- Coolant temperature gauge

2. Switches

- Lights
- Indicators, dimmer & passing
- Wiper & washer
- Hazard lamp
- Fog lamp
- Room lamp
- Warning lamp check
- Map lamp
- Differential lock
- Rear rear differential cross lock
- Mirror heating
- Economy running
- Cruise Control

3. Warning, pilot lamps and buzzers

- Engine oil pressure warning lamp & buzzer
- Air pressure warning lamp & buzzer
- High beam indicator lamp
- Turn signal indicator lamp
- Parking brake indicator lamp
- Coolant level warning lamp & buzzer
- Differential lock indicator lamp
- Engine over-run warning buzzer
- Fuel level warning lamp
- Battery charging indicator lamp
- Fuel filter water level warning lamp
- Transmission splitter range
- ABS warning lamp
- Trailer brake indicator lamp

4. Others

- One key starting-stopping
- Horn button
- Idle up control knob

STEERING

Steering column.	Telescopic & tilt with locking device
Steering box	Recirculating ball with Integral Power Steering
Gear ratio	24.1 - 23.8 - 1
Steering angle	Inside: 48-50° Outside: 39°

CHASSIS FRAME

Type	Ladder-shaped channel section side rails
Rear chassis width.	840mm
Size	279 x 90 x 7.0mm
Tensile strength	620N/mm ² {63kgf/mm ² }
Hook	Equipped for front
Front Underrun Protection	Equipped



SS 2848 Pro-Shift 16 Air Dimensions

700
S E R I E S

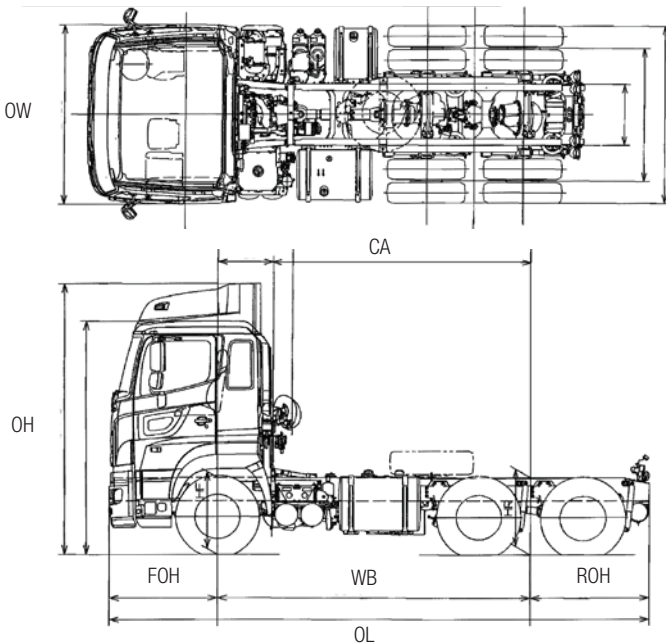

DIMENSIONS – mm / Capacities

Model	Hino SS 2848 Pro-Shift 16 Air
Product code	SS1EKLG-VXZ
Wheelbase (WB)	4005
Overall length (OL)	6895
Overall width (OW)	2490
Overall height (OH)	2995
Cab to rear axle centre (CA)	3295
Front overhang (FOH)	1380
Rear overhang (ROH)	1510
Front chassis height	990
Rear chassis height	1040
Front track	2050
Rear track	1840
Road clearance (at diff. case)	210
Turning circle (kerb to kerb)	15,000
Turning circle (wall to wall)	16,640
Chassis mass – kg (standard tools, 10 litres of fuel, without spare tyre)	
Total	8185
Front	4720
Rear	3465
GVM	28,300
GCM	72,000

GENUINE ACCESSORY OPTIONS

- | | |
|------------------------------|----------------------|
| Bull bar | Side skirts |
| Chrome wheel covers | Step cover kit |
| Sat Nav | Stoneguard |
| Rear vision camera (up to 3) | Woodgrain dash panel |
| Roof spoiler | Transmission PTO |

Please check with your dealer for price, availability & fitment for these options

WARRANTIES

New vehicle warranty period

Heavy Duty Model	Axle configuration	Standard warranty (whichever comes first)	Engine component warranty (whichever comes first)	Cab corrosion perforation
700 SS2848 Pro-Shift 16 Air	6 x 4	3 years or 500,000km	60 months or 750,000km	36 months

Battery warranty – 12 months from date of delivery. Engine component warranty covers, crankshaft, cylinder block and head castings. Genuine parts or accessories warranty – 3 years unlimited kilometres when fitted by an authorised Hino dealer. For conditions, refer to the Hino Parts & Service warranty brochure.

DISCLAIMER

Important notice. Hino Trucks are distributed in Australia by Hino Motor Sales Australia Pty Ltd A.C.N. 064 989 724. All efforts have been made to ensure the information contained in this brochure was correct at time of printing or uploading. Hino Motor Sales Australia Pty Ltd reserves the right to alter any details of the specifications and equipment without notice. Hino in so far as it is permitted by law to do so, shall not be liable in any way as a result of any reliance placed by any person on anything contained in this brochure. You should therefore check with your authorised Hino dealer at the time of ordering your motor vehicle to ensure that colour, specifications, equipment, design features and options are available for the vehicle you are ordering. Please note that some options may only be available in combination with others. Authorised Hino dealers will on request provide up to date information on all accessories, design features, prices and availability.

Date of issue 01/01/12 SS 2848 Pro-Shift 16 Air v3.2