

HINO

500 Series

FM 2632 Auto

FM 2635 Manual



* Illustration may contain items not standard to the model

ADR 80/03 Model

6 x 4 Cab Chassis

KEY FEATURES

- Vehicle Stability Control (VSC) with ASR
- Polished Aluminium Wheels
- Cruise Control
- Hino Stop Start System (HSS) (Manual models only)
- Engine Retarder Brake
- Reverse Camera
- Easy Start (ES) Take off assist (Manual models Only)
- Drivers SRS Airbag
- Heated & Electrically Operated External Mirrors
- ISRI 6860/870 Drivers seat with integrated Safety Belt
- ECE R-29 Cab Strength Certified
- Leaf and Air with ECAS Rear suspension variants
- Differential Cross Locks

KEY SPECIFICATIONS

Models FM 2632 FM 2635
GVM 26,000kg 26,000kg
GCM 36,500kg 45,000kg
Power 320hp/235kW 350hp/257kW
Torque 1,275Nm 1,422Nm
Transmissions Six-speed Nine-speed
 Allison Automatic Synchromesh Manual
Nominal Wheelbases 4.1m, 5.2m, 6.4m	
Max. Nominal Body Length[#] 5.7m, 7.5m, 9.2m	



FM 2632 FM 2635

Engine & Driveline Specifications

ENGINE

Model	FM 2632	FM 2635
Engine Model	A09C-US	A09C-UR
Max. Output (ISO Net) @ 1,800 RPM	320hp/235kW	350hp/257kW
Max. Torque (ISO Net) @ 1,100 RPM	1,275Nm	1,422Nm
Max. Engine Speed	2,100 RPM	
Engine Compliance	ADR 80/03 using Euro 5 STD	
Type	Turbocharged & Intercooled, 6 cylinder in-line, overhead camshaft & fluid cooled	
Combustion System	Direct Injection	
Bore & Stroke	112 x 150mm	
Piston Displacement	8.866L	
Compression Ratio	17.0:1	
Engine Oil Capacity	31.5L	
Coolant Fluid Capacity	Auto: 29.6L Manual: 29.5L	
Fuel Injection System	Electronic control common-rail type	
Air Intake System	Stack-type	
Air Cleaner	Dual paper elements	
Air Compressor	Single cylinder, fluid cooled 85 x 60mm	
Fan Clutch	Equipped	
Exhaust	Horizontal	
Emission Control System	Selective Catalytic Reduction (SCR)	
Hino Stop Start System (HSS)	Manual models only	
Engine Immobilizer	Equipped	

CLUTCH (Manual Models only)

Model	CSP-430
Type	Dry single plate with damper springs
Facing material	Organic
Facing outside diameter	430mm
Control	Hydraulic with air booster

TRANSMISSION & GEAR RATIOS

Make & Description	Automatic		Manual	
	Allison 3200 series 6 speed with Electronic Control		Hino M009 OD 9 speed with Cable Control	
Type	Double Overdrive		Overdrive	
Gear Ratios	1	3.487	1	10.178
	2	1.864	2	6.986
	3	1.409	3	5.063
	4	1.000	4	3.636
	5	0.750	5	2.633
	6	0.653	6	1.921
	Rev	5.027	7	1.392
			8	1.000
			9	0.724
			Rev	9.874
Torque convertor & Ratio	TC 421	1.77		

PERFORMANCE

Calculations based on 26.0 t GVM with 11R22.5 drive tyres			
Transmission	Automatic	Manual	
Wheelbase variants	M, L & XXL	L & XXL	M
Rear Axle Ratio	5.857	4.875	5.250
Engine RPM @ 100 km/h	2,010	1,850	2,000
Max theoretical speed (km/h)	104	114	106
Gradeability tan θ (%) @ GVM	33.8	60	60
Speed limited to (km/h)	100		

BRAKES

Type	Full Air, dual circuit, "S"cam
Drum & Lining sizes	Front : 410 x 150mm
Diameter x Width	Rear : 410 x 220mm
Auto adjusters	Equipped
Vehicle Stability Control (VSC)	Equipped
Anti-lock Braking System (ABS)	Equipped
Anti-Slip Regulator (ASR)	Equipped
Air Dryer	Equipped
Easy Start (ES)	Manual models only
Park Brake	Spring Brake acting on FA & FR axles
Engine Retarder Brake	Equipped

AXLE, SUSPENSION & LOAD LIMITS

Front Axle Model		MF 781R	
Type	I-Beam, Reverse Elliot		
Suspension	Taper leaf springs with shock absorbers & stabiliser		
Spring Dimensions	1,700 x 90 x 28.8mm x 1		
Length x Width x Thickness x Number	1,700 x 70 x 30.3mm x 1		
Spring Rate	32.8 kgf/mm		
Axle Limit (including suspension)	6,500 kg		
Tyre Limit	7,100 kg		
Rear Axle Model	THD17 & SH17		
Differential Cross Lock	Equipped FR & RR		
Inter-axle Differential Lock	Equipped		
Type	Fully floating, single reduction, hypoid		
Rear suspension types	Hino 6 Rod Leaf	Hendrickson Air	
Suspension	Semi-elliptic Multi Leaf	HAS 400 airbag with double acting shock absorbers and ECAS remote height control system	
	Medium	Long & XXL	
Spring Dimensions	1,350 x 90 x 20 x 6	1,350 x 90 x 20 x 6	
Length x Width x Thickness x Number	20 x 10	1,350 x 90 x 18 x 3	Road Friendly Suspension
Spring Rate	293.4 kgf/mm	234.0 kgf/mm	Rating N/o 2005
Axle Limit (including suspension)	20,000 kg		
Tyre Limit	23,200 kg		

WHEELS & TYRES

Material	Polished Aluminium
Wheel type	10-stud disc (ISO) 335 PCD
Rim size (in)	22.5 x 8.25
Tyre size	Front: 295/80R22.5 152/148 Rear: 11R22.5 148/145
Number of tyres	11
Spare Tyre Carrier	Equipped (Except for M wheelbase)

FUEL TANK

Wheelbases	M	L & XXL
Material	Steel	Aluminium
Capacity	200L	390L
Lockable cap	Equipped	
Pre Filter & sedimenter	Equipped	
AdBlue® tank capacity	59L	

STEERING

Type	Telescopic & tilt steering column with locking device. Recirculating ball with internal Power Steering
Steering Angles	Inner 49°
	Outer 34°



FM 2632

FM 2635

Cab, Instrumentation & Chassis

CAB DETAILS

Type	Forward control, all-steel construction mounted on full floating coil spring suspension with electro hydraulic tilt mechanism	
ECE R-29 Cab strength	Compliant	
Drivers SRS Airbag	Equipped	
Seating capacity	Three	
Driver's seat	ISRI 6860/870 with urethane foam pads, high-back, lumbar support, multi adjustable, air suspended, with integrated safety belt	
Side passenger's seat	Urethane foam pads, high-back & reclining seat with fabric cover, air suspension	
Centre passenger's seat	Urethane foam pads & foldaway type with seat back tray, fabric cover	
Seat belt	3-point type on driver's & side passenger's seat 2-point type on centre passenger seat	
Sun visor and overhead console	For driver & passenger sides	
Windshield wipers	Electric, dual, intermittent & 2-speed	
Ventilator	Forced type by electric blower	
Rear view mirrors	External: Electric Control & heated flat type, Convex spotters both sides and Left side kerb view	
12V/120w Socket	Equipped	
Floor mat	Vinyl type	
Central locking & keyless entry	Equipped	
Heater and defroster	Standard	
Air conditioner	Standard	
Trim	Full trim type (side, roof & back)	
Cab pockets	Equipped on both door sides	
Power windows	Equipped	
Rest area	Equipped	
Audio/visual display	DAB+ AM/FM radio with CD & DVD player, Bluetooth and Reverse Camera Display	
Speakers	Driver & passenger	
Foot rest	Equipped	
Easy Start	Manual Models only	
Cup holders	Equipped	
Cruise control	Equipped	

ELECTRICAL

Type	24V, negative earth
Batteries	12V x 2, series connection, 120 Ah
Alternator Type	Brushless, with built-in regulator
Capacity	24V, 90 Amp
Starter Type	24V, 6.0 kW
Headlamps	Halogen type with manual levelling
High/low beam	Equipped
LED Fog Lamps (white)	Equipped
Fluorescent Reading Lamp	Equipped
Electric air horn	Equipped

POWER & TORQUE CHART (ISO Net) A09CUS & A09CUR

A09C-US/A09C-UR

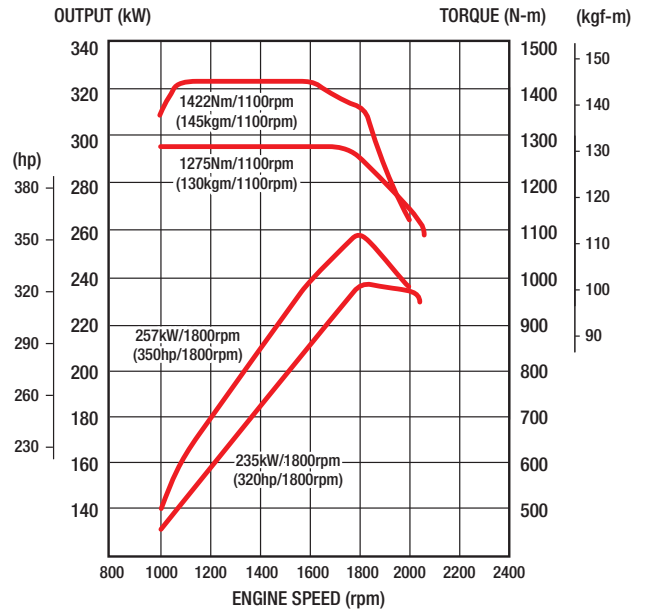

INSTRUMENTS

Meters	Additional Switches & Controls
Speedometer	External flat mirror Control
Tachometer	Easy Start Rate Control (Manual models only)
LCD Gauges	Idle up Control
Air pressure (2)	Quick warm up switch
Fuel	VSC/ASR off switch
AdBlue®	Hino Stop Start System off switch (Manual models only)
Engine Temperature	Eco Run (Manual models only)
Odometer plus trip meter	Headlight Levelling
Multi Information Display (MID)	Fog Lamp
Fuel Consumption	ECAS remote (air bag models)
Service reminders	Inter-axle & Differential Cross Locks
Warnings	Engine Retarder Brake
Faults	

CHASSIS FRAME

Wheelbase variants	M & L	XXL
Type	Ladder-shaped channel section side rails with Grid hole design	
Chassis outer width (at rear)	840mm	
Main section (mm)	298 x 80 x 7.0	300 x 80 x 8.0
Depth x flange x Thickness)		
Tensile strength	620 N/mm ² (63 kgf/mm ²)	
Front Underrun Protection (FUP)	Equipped	
Front and rear tow hook	Equipped	

GENUINE ACCESSORY OPTIONS

Bull bar	GPS Satellite Navigation
Stoneguard	External Vision Cameras (additional 2)
Sunvisor	LED Driving Lights
Seat covers	Hino Traq (Telematics)
Floor mats	Engine driven PTO
Dash mats	1:1 ratio
Weather shields	

Please check with your dealer for price, availability & fitment for these options



FM 2632 FM 2635

500 Series

Dimensions

DIMENSIONS – mm/capacities

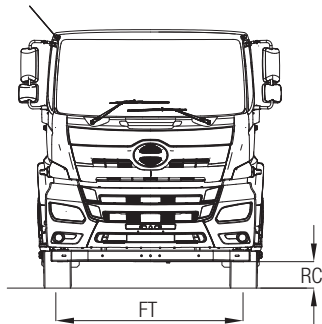

Model	FM 2632						FM 2635					
	WHEELBASE VARIANT	MEDIUM	MEDIUM	LONG	LONG	XXLONG	XXLONG	MEDIUM	MEDIUM	LONG	XXLONG	XXLONG
Transmission	AUTO											
Suspension	MANUAL											
Model Code	LEAF	AIR	LEAF	AIR	LEAF	AIR	LEAF	AIR	LEAF	LEAF	LEAF	AIR
Model Code	FM1AL1M	FM1AL1U	FM1AR1A	FM1AR1G	FM1AW1A	FM1AW1G	FM1AL1M	FM1AL1U	FM1AR1A	FM1AW1A	FM1AW1G	
Wheelbase (WB)	4,155	4,160	5,205	5,210	6,405	6,410	4,155	4,160	5,205	6,405	6,410	
Axles Spread (AS)	1,350	1,330	1,350	1,330	1,350	1,330	1,350	1,330	1,350		1,330	
Max Nominal Body length # (WB x 0.6(up to 3.7)) + CA – 80)	5,713	5,721	7,518	7,526	9,295	9,300	5,838	5,846	7,518	9,295	9,300	
Overall Length (OL)	7,845		9,295		11,245		7,845		9,295		11,245	
Overall Width (OW)	2,490											
Overall Height (OH)	2,905			2,900			2,905		2,900		2,895	
Cab to Rear Axle Centre (CA)	3,300	3,305	4,475	4,480	5,675	5,680	3,425	3,430	4,475	5,675	5,680	
Front Overhang (FOH)	1,380											
Rear Overhang (ROH)	2,250	2,245	2,650	2,645	3,400	3,395	2,250	2,245	2,650	3,400	3,395	
Front Chassis Height (FCH)	1,025			1,020			1,025		1,020		1,015	
Rear Chassis Height (RCH)	1,070	1,045	1,070	1,045	1,070	1,045	1,075	1,045	1,070		1,045	
Road Clearance (RC)	250											
Front Track (FT)	2,050											
Rear Track (RT)	1,855	1,840	1,855	1,840	1,855	1,840	1,855	1,840	1,855		1,840	
Turning Circle Kerb to Kerb	15,400		18,600		22,400		15,400		18,600		22,400	
Wall to Wall	17,000		20,200		24,000		17,000		20,200		24,000	
Indicative Chassis Mass – kg (10 litres of fuel & spare tyre and subject to ± 3% Tolerance)												
Total	7,496	7,048	7,572	7,182	7,777	7,392	7,536	7,083	7,667	7,867	7,487	
Front	3,798	3,780	3,832	3,828	3,916	3,917	3,818	3,800	3,902	3,991	3,997	
Rear	3,698	3,268	3,740	3,354	3,861	3,475	3,718	3,283	3,765	3,876	3,490	
GVM	26,000											
GCM	36,500						45,000					

ROH may need to be extended to suit body length and rear overhang is limited to 3.7 m

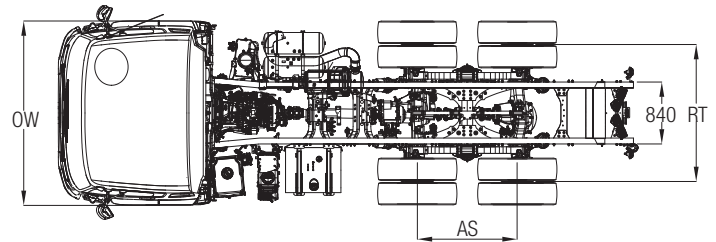
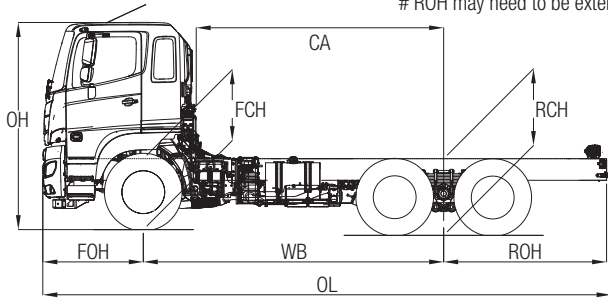

WARRANTY

New vehicle warranty period

Medium Duty Model	Axle configuration	Standard warranty (whichever comes first)	Cab corrosion perforation
500 FM 2632 & FM 2635	6 x 4	3 years or 200,000km	36 months

Battery warranty – 12 months from date of delivery

* For conditions, refer to the Hino Parts & Service warranty brochure

Genuine parts or accessories warranty – 3 years unlimited kilometres when fitted by an authorised Hino dealer *



DISCLAIMER

Important notice. Hino Trucks are distributed in Australia by Hino Motor Sales Australia Pty Ltd A.C.N. 064 989 724.

All efforts have been made to ensure the information contained in this brochure was correct at time of printing or uploading. Hino Motor Sales Australia Pty Ltd reserves the right to alter any details of the specifications & equipment without notice. Hino in so far as it is permitted by law to do so, shall not be liable in any way as a result of any reliance placed by any person on anything contained in this brochure. You should therefore check with your authorised Hino dealer at the time of ordering your motor vehicle to ensure that colour, specifications, equipment, design features & options are available for the vehicle you are ordering. Please note that some options may only be available in combination with others. Authorised Hino dealers will on request provide up to date information on all accessories, design features, prices & availability.

HSMY17FM2632FM2635-0217